

CAUTION: Always wear safety goggles when performing any maintenance work.

90.8 / 90.10 / 90.10RX / 90.5B2 Series Gas Spring Repair Instructions

I. Exhausting Pressure

Self-Contained Mode



1. When exhausting pressure, position the gas spring horizontally with the port up for safety.



2. Remove the Port Plug (90.505.110) located at the base of the spring. Retain parts for use during reassembly.



3. Keeping face and hands clear of the port, use the Valve Bleed Tool (90.360.4) or the Port Servicing Tool (90.320.8) to depress the Compact Valve (90.260) or Cartridge Valve (90.265). Cover the port with a cloth to absorb discharge.



4. After all of the gas pressure is exhausted, be sure that the piston rod will freely extend and retract into the tube manually. If not, try depressing the valve again. If still unsuccessful, **STOP** and contact DADCO.

Linked Mode



1. Exhaust nitrogen gas by opening the bleed valve on the control panel.



2. Verify that all pressure is relieved by manually retracting the piston rod into the tube. If the rod will not fully retract release the remaining pressure. If still unsuccessful, **STOP** and contact DADCO.



3. Unthread the service fitting and wipe with a clean cloth. Proceed to "II. Port Maintenance" *Linked Mode*, step 1.

II. Port Maintenance

Self-Contained Mode



1. Generally the valve does not need replacing. If the valve appears damaged, is leaking pressure, or is sticking, proceed to step 2. If the valve does not need replacing, proceed to "III. C-Ring Removal".



2. Remove valve using the Port Servicing Tool (90.320.8). Compact Valve (90.260) requires a T20 drive or bit, Cartridge Valve (90.265) requires a T40 drive or bit.



3. Replace the damaged valve. Use the Port Servicing Tool (90.320.8) to thread the new valve into the port until it fits snugly on the seat. Avoid over torquing the valve.

Linked Mode



1. Check the port for deposits or burrs and clean thoroughly. Inspect the service fitting and replace if it shows signs of damage. Lubricate threads and seals on the fitting and thread the service fitting into the gas spring port.

III. C-Ring Removal



1. Stand the gas spring upright. Make sure the rod is retracted in the tube. Place a Removal Sleeve (90.340.x) over the rod. Tap the sleeve until the Dust Cover (90.246.x) is loosened. Remove the Dust Cover and discard.



2. Reposition the Removal Sleeve and continue tapping until the rod cartridge assembly is slightly below the Retaining Ring groove. DO NOT force the cartridge down further into the Tube Assembly.



3. Remove the C-style Retaining Ring (90.285.x) using the C-Ring Removal Tool (90.355 or 90.356). Position the correct hooked end of the C-Ring Removal Tool below the c-ring. For best results lay cylinder horizontally and locate the tool near either end of the c-ring. See bulletin B15127A for more information.



4. Once the hooked end of the tool is firmly seated below the c-ring, begin pushing it toward the outside of the gas spring can. The handles will close naturally, and the c-ring will be extracted as you complete this motion.

IV. Rod & Cartridge Removal



1. To remove the Cartridge Assembly, thread a T-Handle (90.320.x) into the rod end.



2. Pull the entire assembly out of the tube. Depress the cartridge valve to relieve any back pressure.



3. Once the cartridge and rod are removed from the Tube Assembly, slide the cartridge off of the rod and discard. Retain rod for inspection and possible reuse.

V. Cleaning & Inspection



1. Lightly polish the rod surface with an emery cloth (600 grit). Inspect the finish of the rod for any scratches or gouges. If the rod is damaged it must be replaced. If present, the Rod Safety Ring should remain in place.



2. Inspect the Tube Assembly for any damage, especially around the mouth of the Tube Assembly. Polish out any scratches at the mouth of the tube assembly to avoid damaging seals during the reassembly process. If damage to the Tube Assembly is severe it must be replaced.



3. Wash, clean and dry the inside of the Tube Assembly thoroughly.

CAUTION: Before starting the reassembly process, be sure the repair area is clean. It is imperative that the gas spring be free of all contaminants upon reassembly. If this precaution is not taken it may lead to premature failure of the gas spring.

VI. Cartridge Replacement and Reassembly



1. Choose the appropriate repair kit (90.201.x or 90.208.x) for the specific model you are repairing. The repair kit number is laser marked on the back of the tube assembly.



2. Thread Assembly Cone (90.331.x) from Cartridge Starter Kit (90.335.x) onto rod. Slide Cartridge Assembly over the Assembly Cone, making sure that the wiper end marked "TOP" is facing up. Place Cartridge Assembly Cap (90.330.x) from Cartridge Starter Kit (90.335.x) on top of Cartridge Assembly.

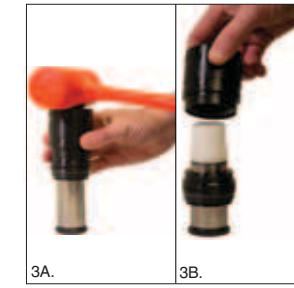

3A. While holding the cartridge, vertically tap the Assembly Cap to drive the cartridge down the rod. Be careful not to force the cartridge at an angle as the seal could become damaged.

3B. The cartridge is now below the Assembly Cone. Remove Assembly Cone from the rod.



4. Lubricate the inside wall of the tube with entire contents of the bottle of assembly oil.



5. Place the rod and cartridge assembly into the spring. To release any back pressure, depress the cartridge valve. Use the Assembly Cap (90.330.x) to drive the rod and cartridge assembly into the tube assembly.



6. Position the top of the cartridge just below the retaining ring groove. The assembly cap is designed to locate the cartridge in this position.



7. Insert the C-Style Retaining Ring (90.285.x) in the retaining ring groove using a DADCO C-Ring Installation Tool (90.350.x, 90.351.x or 90.352) or standard bench tools. Be sure C-Style Retaining Ring is fully seated in retaining ring groove.



8. Thread T-Handle (90.320.x) into the end of the piston rod. Pull up on T-Handle until the top of the cartridge is past the c-ring. The rod must seat cartridge assembly fully (with the housing flush with end of cylinder). Make sure rod is extended to its proper stroke length. (Depress cartridge valve to facilitate full rod extension.)

VII. Charging

Quick Disconnect Filling Method

NOTE: For best results, use the DADCO Charging Assembly which has a shut off valve and a quick disconnect charging nipple at the end of the hose.

Self-Contained Mode



1S. Thread the Quick Disconnect Charging Nipple (90.310.111) into the port of the gas spring. Connect the female end of the Charging Assembly (90.310.040 or 90.310.045) to the charging nipple. The DADCO Pressure Analyzer (90.315.5) can also be used for charging, discharging and gauging the pressure.

Linked Mode



1L. Pipe all gas springs back to the control panel, making sure that all connections are tight and that gas spring rods are extended.



2L. Attach Charging Assembly (90.310.040 or 90.310.045) to the quick disconnect filler valve on the control panel.

Self-Contained or Linked Mode



3. Open the main valve on the nitrogen tank.



4. Set the desired charging pressure on the regulator.



5. Slowly open the shut-off valve and allow gas spring to reach the desired charging pressure. After the gas spring has been charged to the desired pressure, CLOSE THE HOSE SHUT-OFF VALVE AND THE TANK SHUT-OFF VALVE.



6. Disconnect the charging assembly from the charging nipple. The small amount of nitrogen trapped between the shut-off valve and filler valve will bleed off as you disconnect the fitting.

Self-Contained or Linked

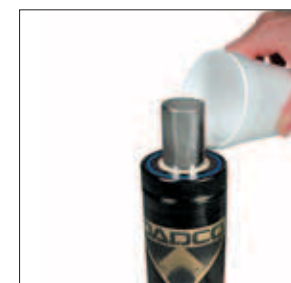

7. Check for leaks at the top of the tube around the rod and at the base around the valve compartment using vegetable oil or water.

Self-Contained Mode



8S. Verify the pressure with a DADCO Load Cell using a Portable Test Stand (90.305.3) or an arbor press.

Self-Contained or Linked



9S. Make sure the valve is in place and thread Port Plug (90.505.110) securely over top.

Self-Contained or Linked



10. Install the new Dust Cover (90.246.x). Tap with a soft mallet until the top of the Dust Cover rests flush with the top of the can. The rod wiper should be visible.

VIII. Adjusting Gas Spring Pressure

Self-Contained Mode

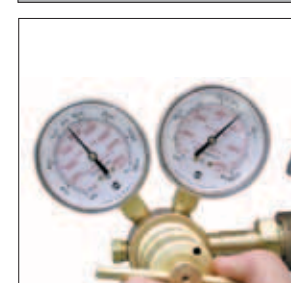

1S. To increase spring pressure, thread the Quick Disconnect Charging Nipple (90.310.111) into the port, set the regulator to the desired pressure and fill. DADCO's Pressure Analyzer (90.315.5) may also be used to adjust pressure.



2S. To decrease gas spring pressure, depress the valve stem using a Valve Bleed Tool (90.360.4).

Linked Mode



1L. To increase system pressure, set the regulator on the nitrogen tank to the desired level and fill the system through the control panel. To release pressure, open the drain valve on the control panel.

90.8 Series Parts List

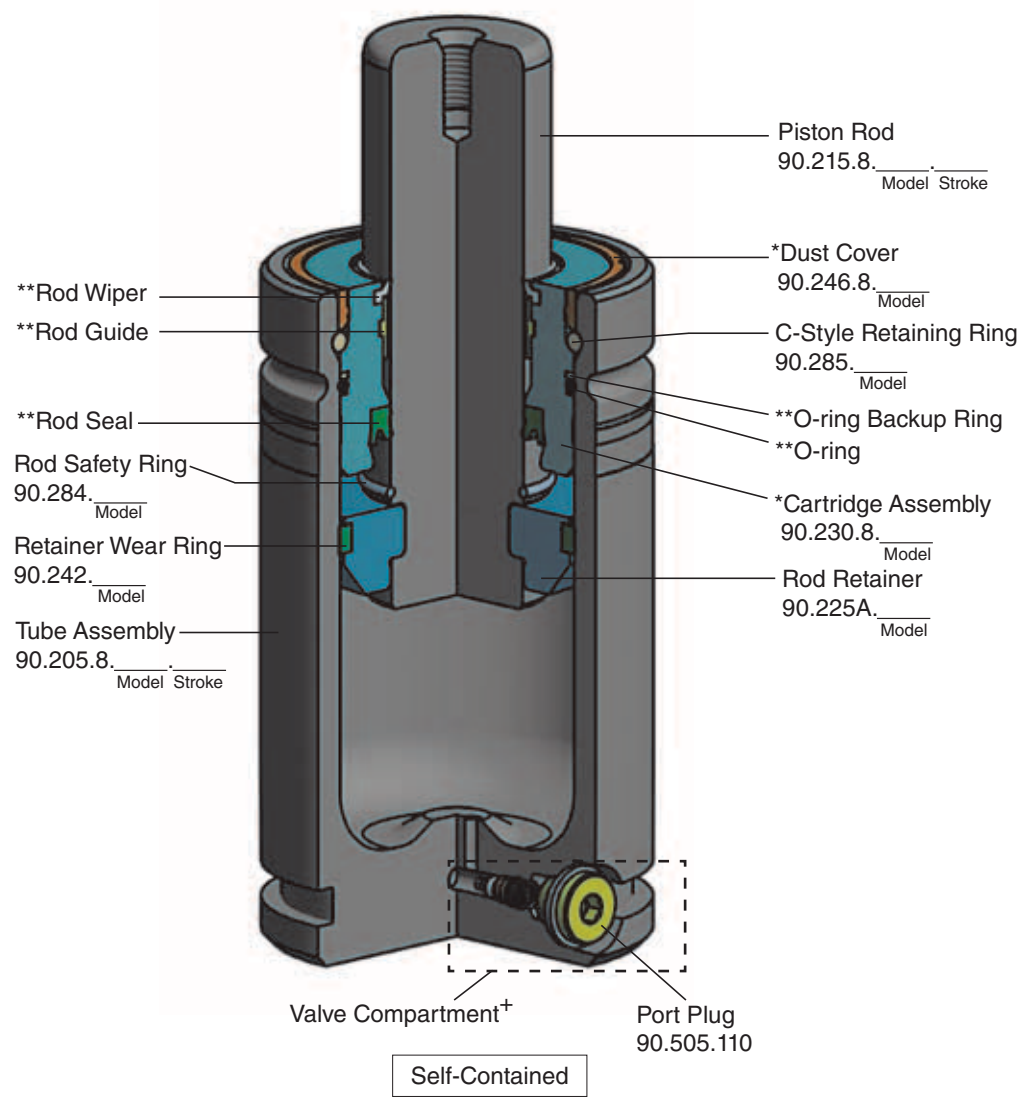

*Included in the Repair Kit
 **Included in the Cartridge Assembly

90.10 / 90.10RX Series Parts List

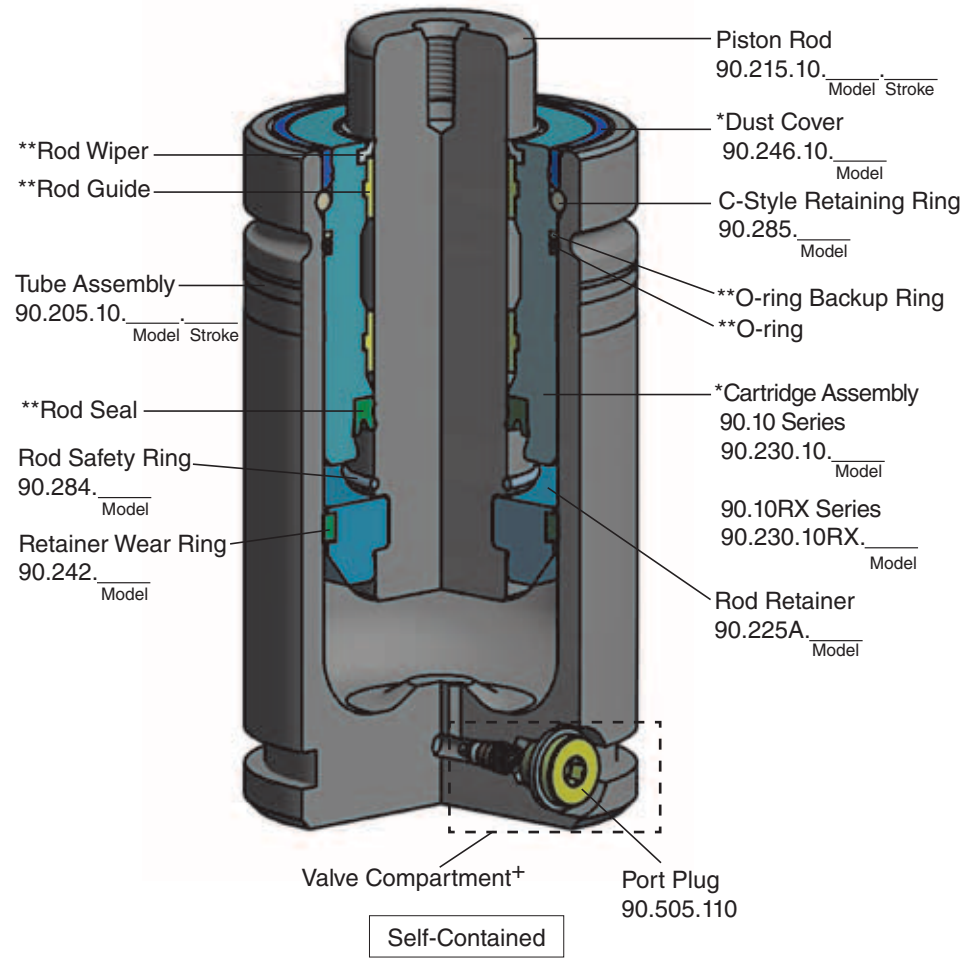

*Included in the Repair Kit
 **Included in the Cartridge Assembly

90.5B2 Series Parts List

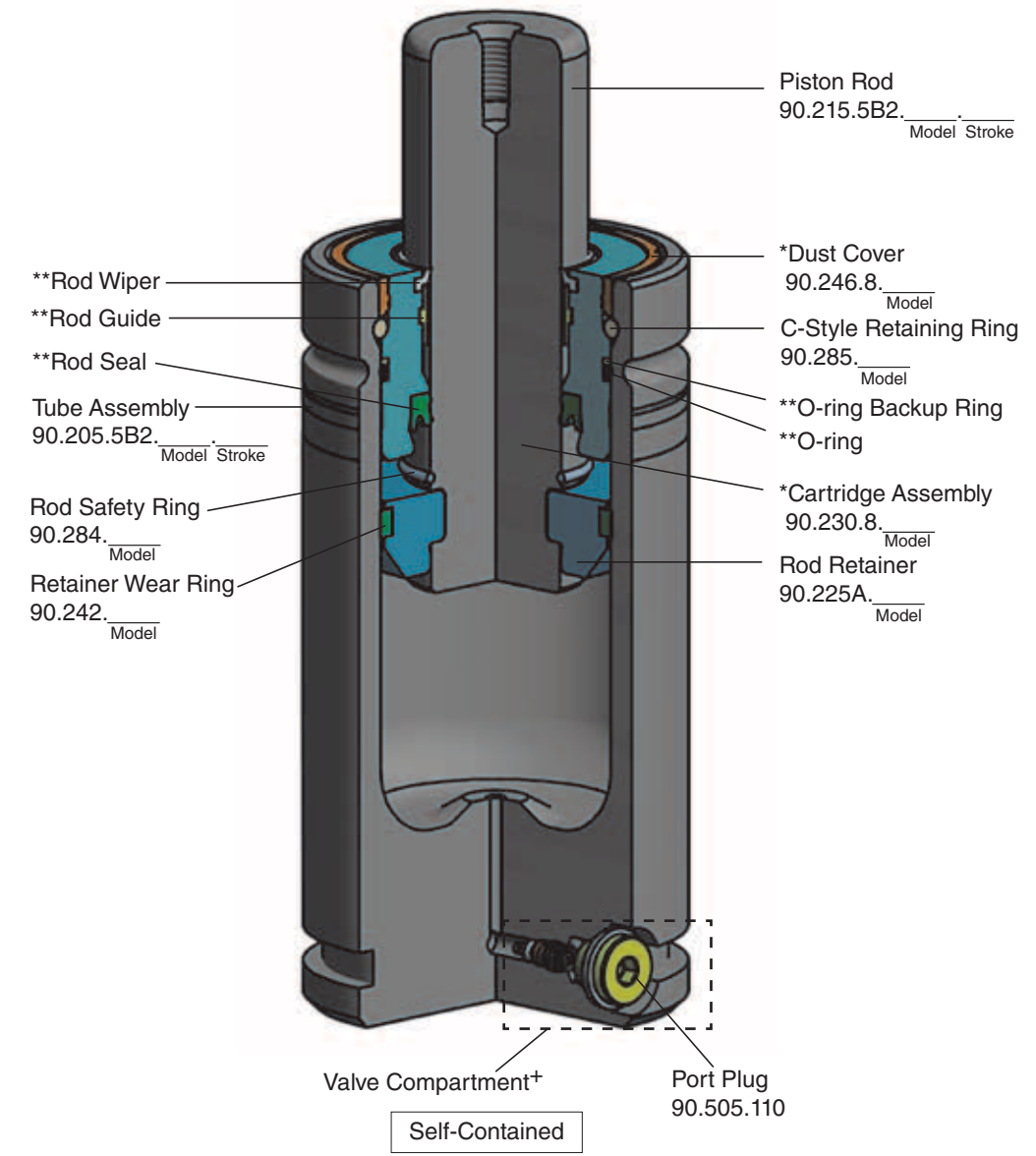

*Included in the Repair Kit
 **Included in the Cartridge Assembly

Valve Compartment⁺ 90.8 / 90.10 / 90.10RX / 90.5B2

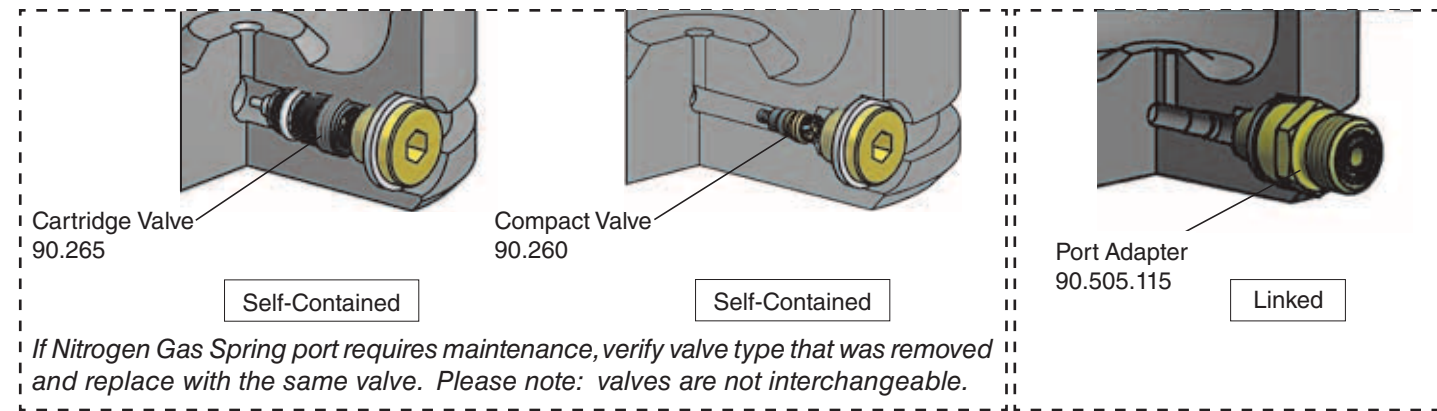

Repair Tools

Cartridge Starter Kit 90.335 _____

(00500, 00750, 01500, 03000, 05000, 07500, 10000)

The Cartridge Starter Kit includes an Assembly Cap and an Assembly Cone. The Assembly Cone is used to start the cartridge assembly onto the rod without damaging the seal, the Assembly Cap is used to set the cartridge at a proper depth for C-Ring installation.



C-Ring Installation Tool 90.351.00500 (00500 Model) 90.350.00750 (00750 Models)

To insert the C-style retaining ring into the retaining ring groove.



T-Handle 90.320.2 – M8 thread 90.320.10 – M10 thread

To remove the piston rod when disassembling and position correctly when reassembling.



Valve Bleed Tool 90.360.4

Use the DADCO Valve Bleed Tool to slowly discharge a spring to the desired pressure.



Port Servicing Tool 90.320.8

To perform all necessary servicing to the valve compartment.



Quick Disconnect Charging Nipple 90.310.111 (G 1/8)

Use the DADCO Quick Disconnect Charging Nipple to charge Nitrogen Gas Springs.



Standard Load Cell 90.300 _____ (00500, 00750, 01500, 03000, 05000, 07500, 10000)

The Standard Load Cell gives precise measurement of gas spring charging pressure. Each model requires its specified load cell. Load cells for 00500 – 07500 Models may be used with the Portable Test Stand; the load cell for the 90.10.10000 may be used with an arbor press. For more information, request bulletin B16119A.



Removal Sleeve 90.340 _____

(00500, 00750, 01500, 03000, 05000, 07500, 10000)

To position the cartridge below the C-ring groove when assembling or disassembling a gas spring.



C-Ring Installation Tool 90.352 (01500 – 10000 Models)

To insert the C-style retaining ring into the retaining ring groove.



C-Ring Removal Tool 90.355 (00500 – 03000 Models) 90.356 (00750 – 10000 Models)

To remove the C-style retaining ring safely in a single controlled motion. *Note: Use 90.356 for 90.8/10.00750 models.*



DADCO Pressure Analyzer 90.315.5

Use the DADCO Pressure Analyzer to easily charge, discharge, and gauge the pressure in DADCO's Nitrogen Gas Springs.



Charging Assembly 90.310.040

Use the DADCO Quick Disconnect Charging Assembly with the Charging Nipple or Pressure Analyzer to charge self-contained gas springs. The 90.310.040 can also be used with a DADCO control panel for charging linked systems.



Portable Test Stand 90.305.3

Use the Portable Test Stand in conjunction with a Standard Load Cell for precise measurement of gas spring force. For more information request bulletin B16112A.



Bulletin No. B06124H

Comprehensive Guide

This service manual is a simple step-by-step maintenance guide for DADCO Nitrogen Gas Spring models including the 90.8, 90.10, 90.10RX and 90.5B2 Series.

Proper repair requires careful examination of all component parts and replacement of any that are worn or damaged. All DADCO replacement parts are available from factory stock.

Typically, DADCO Nitrogen Gas Springs can be rebuilt in less than ten minutes by replacing only one part, the factory pre-assembled cartridge assembly.

After reviewing this maintenance guide, if you require any additional training or have any questions please contact DADCO for assistance.

Please Note: Nitrogen Gas Spring repair varies slightly from model to model and by mode of operation (self-contained or linked). As you proceed through the basic steps outlined in this bulletin, take care to follow the instructions pertaining to your model. All DADCO Gas Springs are permanently marked with model and serial number. Please refer to these numbers when performing repair work and when ordering replacement parts.

©DADCO, Inc. 2020 • All Rights Reserved



Nitrogen Gas Spring Maintenance Instructions 90.8 / 90.10 / 90.10RX / 90.5B2 Series



43850 Plymouth Oaks Blvd.
 Plymouth, Michigan USA 48170
 1.734.207.1100 • 800.323.2687
 Toll Free: 800.DADCO.USA
 Fax: 1.734.207.2222
 www.dadco.net