

Use the new Cinch-Lock bolt and urethane ring set to secure DADCO gas springs in a pocket without additional mounting components.

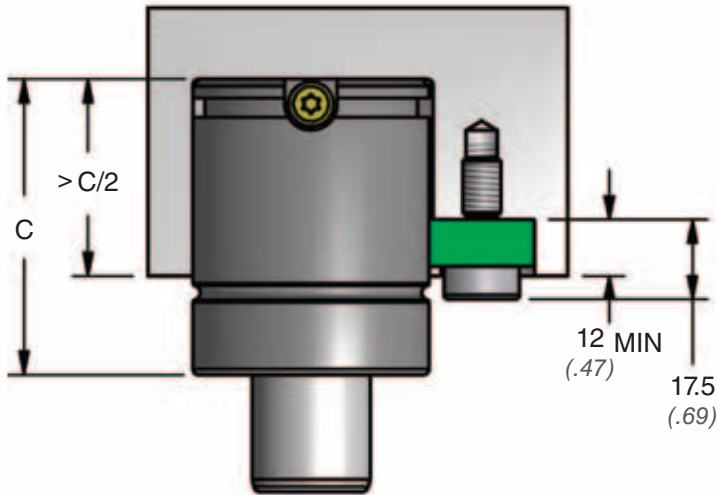

For "C" Dimension, refer to appropriate DADCO product catalog.

### Save space over bulky mounts

- Easily remove spring while still in the press
- Mount gas springs without studs or screws
- Available in metric or imperial thread

Cinch-Lock must be secured using the following torque specification:

90.13M	247 lb·in / 28 N·m
90.13E	194 lb·in / 22 N·m

### Cinch-Lock 90.13M (8 mm Tap) 90.13E (5/16"-18 Tap)

øD	A
15 mm	18.25 .719
19 mm	20.25 .797
25 mm	23.25 .915
32 mm	26.75 1.053
38 mm	29.75 1.171
44.5 mm	33.00 1.299
50 mm	35.75 1.407

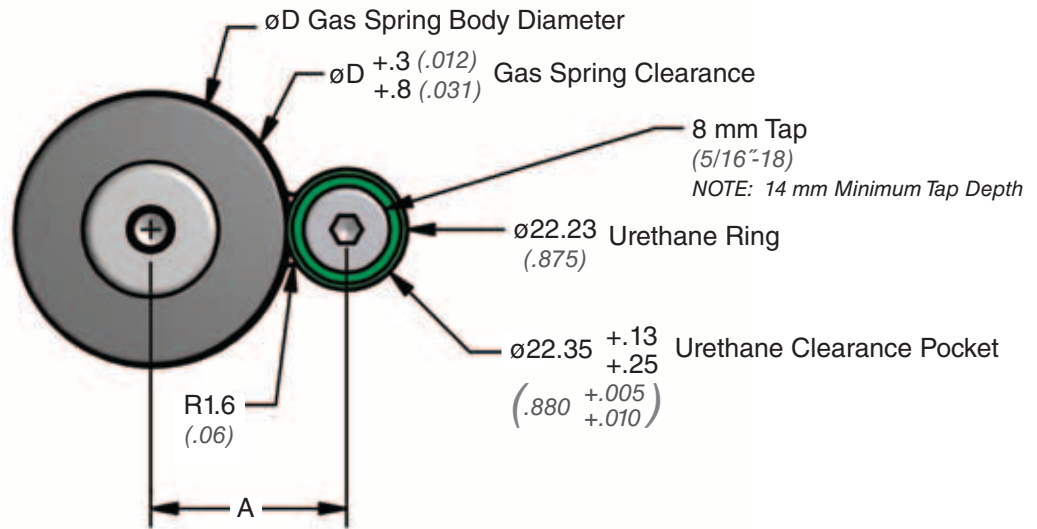

### Installation Guidelines

- Install Cinch-Lock next to the gas spring
- Completely tighten bolt so urethane piece touches the gas spring
- **For use with gas springs 50 mm in body diameter and smaller**
- Recommended for use with self-contained gas springs only