

DADCO®

Ultra Force® Nitrogen Gas Springs

U Series



Ultra Force, Low Profile Gas Springs!

- Up to 22 tons of force on contact
- UltraPak® cartridge for long life
- Operates self-contained or linked



DADCO®

The global leader in nitrogen gas spring technology

DADCO produces top quality products at competitive prices and provides a superior level of customer service. Founded in 1958, DADCO is the highest volume producer of gas springs for press tools. DADCO's products are widely approved and used in global operations for many industries including metal stamping, automotive and plastic injection molding.



High Force + Compact Height = Ultra Force®

DADCO's **Ultra Force®** (U Series) Gas Springs are ideal for stampers constrained by limited shut height. The U Series Gas Springs provide high force in compact height, offering up to 22 tons of force on contact. Many sizes, stroke lengths and mount options are available for new or existing applications.

Model	Diameter	Maximum Force on Contact		
		lb.	daN	ton
U.0175	19 mm (0.750")	383 lb.	171 daN	0.19 ton
U.0325	25 mm (0.984")	715 lb.	320 daN	0.35 ton
U.0400	32 mm (1.260")	810 lb.	362 daN	0.4 ton
U.0600	38 mm (1.496")	1059 lb.	471 daN	0.5 ton
U.0800	44.5 mm (1.750")	1655 lb.	736 daN	0.7 ton
U.1000	50 mm (1.968")	2076 lb.	9.24 kN	1.0 ton
U.1200	50 mm (1.968")	2383 lb.	10.60 kN	1.2 ton
U.1600	63 mm (2.480")	3432 lb.	15.27 kN	1.7 ton
U.2600	75 mm (2.953")	5362 lb.	23.86 kN	2.6 ton
U.4600	95 mm (3.740")	9532 lb.	42.41 kN	4.7 ton
U.6600	120 mm (4.724")	14894 lb.	66.27 kN	7.4 ton
U.9600	150 mm (5.906")	21447 lb.	95.43 kN	10.7 ton
U.20000	195 mm (7.670")	44747 lb.	199.10 kN	22 ton

High Quality Construction

To ensure their exceptionally long service life, DADCO's U Series Gas Springs have high quality construction features. U.0400 to U.20000 models are built with a one-piece piston rod and utilize a double lip rod seal for excellent load capacity and resistance to wear.

Adjustable Force

For convenience, self-contained cylinders usually are delivered pre-charged to the desired force and ready to install. If force adjustment is ever needed, a filling/draining port is located in the cylinder for safe, easy access.

UltraPak® Technology (U.0400 - U.20000)

The U Series incorporates superior gas spring technology into DADCO's **UltraPak®** cartridge. The **UltraPak®** employs advanced materials to reduce the rod cartridge profile while increasing performance. The **UltraPak®** is comprised of a rod wiper, rod seal and guide arranged to extend life, retain lubrication, exclude contaminants, and provide excellent wear characteristics. When coupled with DADCO's superior finished piston rod, the **UltraPak®** is the ultimate sealing system in compact height gas springs.

Numerous Piping Options

Many customers have recognized the benefits of piping gas springs to monitor, control, and adjust force from outside the die. DADCO offers a wide selection of hoses, fittings, control panels and equipment to simplify the piping process. For additional information on piping see page 34.



Customer Satisfaction

DADCO's motto is "Whatever It Takes To Satisfy Our Customers." DADCO will assist in any way possible to ensure that customers are completely satisfied. DADCO's salespeople and distributors are solution-oriented, product-knowledgeable, and eager to assist customers. DADCO's engineers are available to help customers with specific applications.

Rapid Delivery

DADCO's modern 13,150 m² main production facility as well as satellite facilities permit the fastest deliveries in the industry. Products are available both directly and through a network of trained distributors providing worldwide support.

Warranty

DADCO warrants its U Series Nitrogen Gas Springs to be free from defects in workmanship or materials for a period of one year from date of manufacture.

CAD Templates On-line

DADCO's entire product line is available on-line in solid models and 2D CAD formats. For more information, visit our website, www.dadco.net, or contact DADCO.

Installation Examples

DADCO offers a variety of mount options to meet specific customer applications. Installation and fastening of the gas springs should take into consideration load support, fastener selection and torque values. For additional information on installation requirements see page 35. Cylinder and mount dimensions are shown on pages 4-29.

U.0175/U.0325:
 $\phi D +.1 (.004)$
 $+ .4 (.016)$
U.0400-U.20000:
 $\phi D +.3 (.012)$
 $+ .8 (.031)$

TO Basic Model in a flat bottom pocket. The pocket must be bored with a flat bottom, or a spacer must be used to create a flat surface.

U.0175 - U.0325 U.0400 - U.20000

TO Basic Model mounted inverted requires back-up to support the full load. Retain inverted cylinders tight in the pocket with the appropriate length cap screw to eliminate movement.

M6 Port

G1/8 Port

TO Basic Model mounted to a plate. Linked cylinders require clearance for the hose and fittings.

B12/B112/B212/B312 mounts must be fastened to the bottom groove only. Back-up is required to support the full load.

FA/RF/B21/B25/B321/B322/B325 mounts must be fastened to the top groove only. The wire ring supplied with mounts supports the full load.

B19/B319/B319V mounts require back-up to support the load.

U.0175/U.0325:
 $\phi D +.1 (.004)$
 $+ .4 (.016)$
U.0400-U.20000:
 $\phi D +.3 (.012)$
 $+ .8 (.031)$

TO Basic Model mounted in a horizontal pocket. Allow clearance in the rod pocket to avoid contacting the body of the cylinder during operation. Allow the rod to locate freely.

DADCO offers customized Sectional Mounting Systems (SMS®), which are fabricated to customer specifications, leak tested and shipped ready to install.

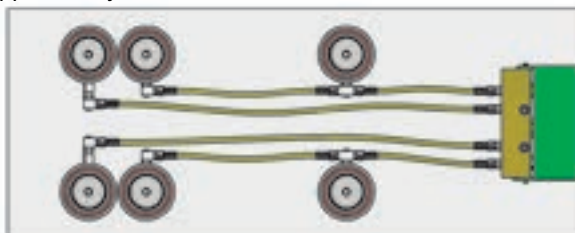

Six U.2600 gas springs linked using DADCO's *MINILink*® System which includes Y-700 hose, fittings and a Mini Control Panel.

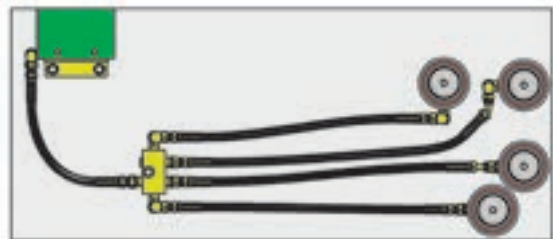

Four U.4600 gas springs linked using DADCO's Y-400 hose, fittings and a Common Control Panel.

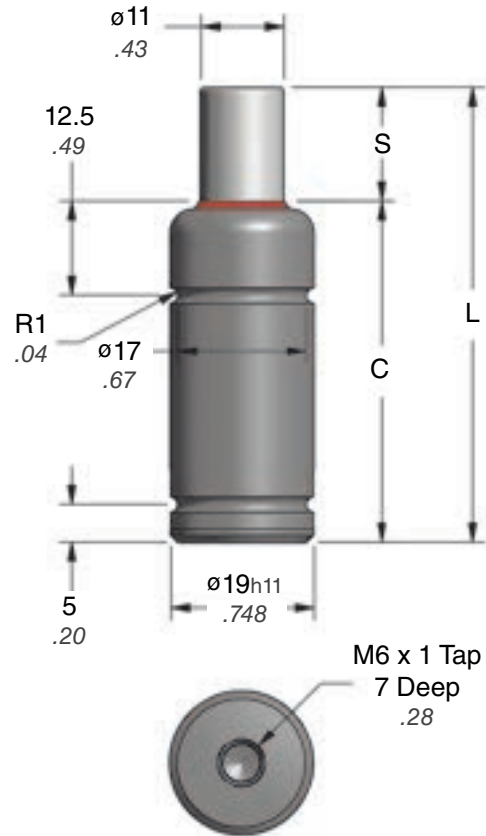

TO - Basic Model

For longer strokes and lower force applications consider C.090, Micro Catalog (C12118F).

Part No.	S mm inch	C	L ±0.4 ±0.015
U.0175.007	7 0.28	37 1.46	44 1.732
• U.0175.010	10 0.39	40 1.57	50 1.969
U.0175.013	12.7 0.50	42.7 1.68	55.4 2.181
• U.0175.015	15 0.59	45 1.77	60 2.362
U.0175.019	19 0.75	49 1.93	68 2.677
• U.0175.025	25 0.98	55 2.17	80 3.150
• U.0175.038	38 1.50	68 2.68	106 4.173
• U.0175.050	50 1.97	80 3.15	130 5.118
U.0175.063	63.5 2.50	93.5 3.68	157 6.181
U.0175.075	75 2.95	110 4.33	185 7.283
• U.0175.080	80 3.15	115 4.53	195 7.677
U.0175.100	100 3.94	135 5.31	235 9.252
U.0175.125	125 4.92	160 6.30	285 11.220

• Preferred Sizes

Ordering Example:

U.0175.025. TO. 180

Part Number: _____

Includes Series, Model and Stroke Length.

Mount Option: _____

Charging Pressure:

15–180 bar (220–2600 psi).

When not specified, default is 180 bar.

TO = Basic Model. When not specified, default is TO.

RM, FA, VFA and RF mounts ordered with cylinder will be attached at the factory.

Refer to page 34 for information on linking.

U.0175 — 170 daN / 0.19 ton

U.0175 Force Charts

On-Contact Force

psi	lb.
2600	383
2175	320
2000	295
1750	258
1500	221
1000	147
500	74
250	37

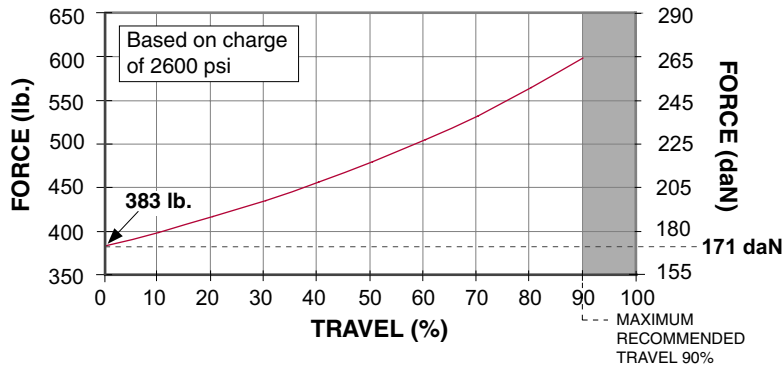

On-Contact Force

bar	daN
180	171
150	143
125	119
100	95
75	71
50	48
25	24
20	19

Mount Options

RM **C90-RM**

SLIDE MOUNT INTO DESIRED LOCATION AND LOCK

VFA **C90-VFA**

SPLIT WIRE RING INCLUDED 90.55.090

SECURE MOUNT ONTO TOP GROOVE WITH SUPPLIED RING AND SCREWS

FA **C90-FA**

SECURE MOUNT ONTO TOP GROOVE WITH SUPPLIED RING AND SCREWS

RF **C90-RF**

SECURE MOUNT ONTO TOP GROOVE WITH SUPPLIED RING AND SCREWS

Ordering Example:

Cylinder with Mount: U.0175.025.RM.180

Mount Only: C90-RM

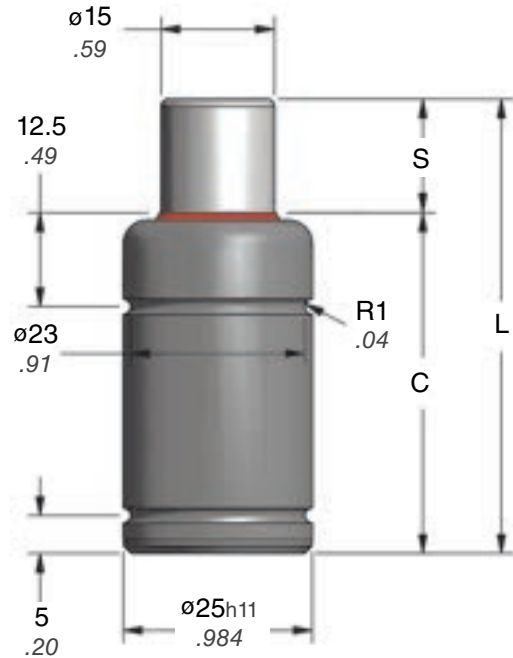

Part No.	S mm inch	C	L ±0.4 ±0.015
U.0325.007	7 0.28	37 1.46	44 1.732
• U.0325.010	10 0.39	40 1.57	50 1.969
U.0325.013	12.7 0.50	42.7 1.68	55.4 2.181
• U.0325.015	15 0.59	45 1.77	60 2.362
U.0325.019	19 0.75	49 1.93	68 2.677
• U.0325.025	25 0.98	55 2.17	80 3.150
• U.0325.038	38 1.50	68 2.68	106 4.173
• U.0325.050	50 1.97	80 3.15	130 5.118
U.0325.063	63.5 2.50	93.5 3.68	157 6.181
U.0325.075	75 2.95	110 4.33	185 7.283
• U.0325.080	80 3.15	115 4.53	195 7.677
U.0325.100	100 3.94	135 5.31	235 9.252
U.0325.125	125 4.92	160 6.30	285 11.220

• Preferred Sizes

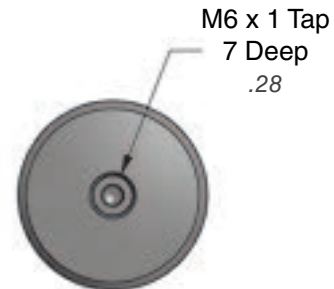

TO - Basic Model

For longer strokes and lower force applications consider C.180, Micro Catalog (C12118F).

Ordering Example:

U.0325.025. TO. 180

Part Number:

Includes Series, Model and Stroke Length.

Mount Option:

TO = Basic Model. When not specified, default is TO.

RM, FA, VFA and RF mounts ordered with cylinder will be attached at the factory.

Charging Pressure:

15–180 bar (220–2600 psi).

When not specified, default is 180 bar.

Refer to page 34 for information on linking.

U.0325 — 320 daN / 0.35 ton

U.0325 Force Charts

On-Contact Force

psi	lb.
2600	715
2175	596
2000	548
1750	479
1500	411
1000	274
500	137
250	68

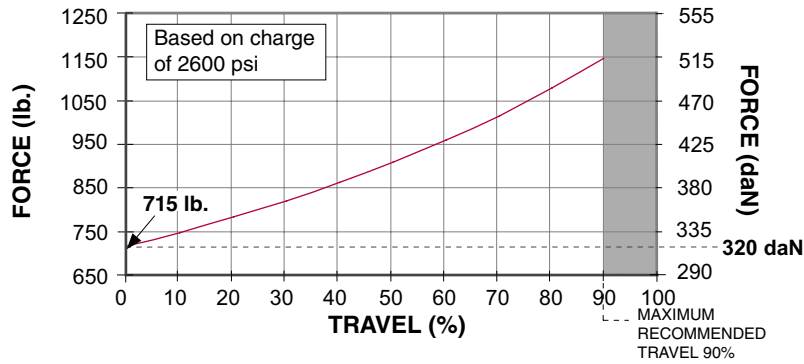

On-Contact Force

bar	daN
180	320
150	265
125	221
100	177
75	133
50	88
25	44
20	35

Mount Options

RM **C180-RM**

ø50 1.97

ø38.1 BOLT CIRCLE 1.500

2 x M5 SHCS #10 SHCS

12.7 .50

SLIDE MOUNT INTO DESIRED LOCATION AND LOCK

VFA **C180-VFA**

50 1.97

30 1.18

38 1.496

2 x ø6.6 .26

17 .67

9 .35

Split Wire Ring Included 90.55.180

SECURE MOUNT ONTO TOP GROOVE WITH SUPPLIED RING AND SCREWS

FA **C180-FA**

28.5 1.13

34 1.339

50 1.97

18 .709

17 .67

9 .35

4 x M6 SHCS 1/4 SHCS

Split Wire Ring Included 90.55.180

SECURE MOUNT ONTO TOP GROOVE WITH SUPPLIED RING AND SCREWS

RF **C180-RF**

ø38 BOLT CIRCLE 1.496

50 1.97

26.9 1.058

17 .67

9 .35

4 x M6 SHCS 1/4 SHCS

Split Wire Ring Included 90.55.180

SECURE MOUNT ONTO TOP GROOVE WITH SUPPLIED RING AND SCREWS

Ordering Example:

Cylinder with Mount: U.0325.025.RM.180

Mount Only: C180-RM

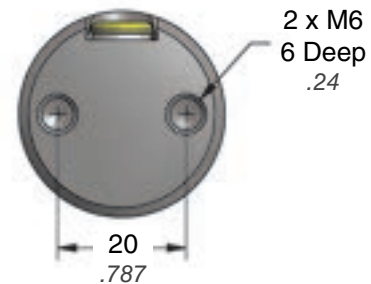
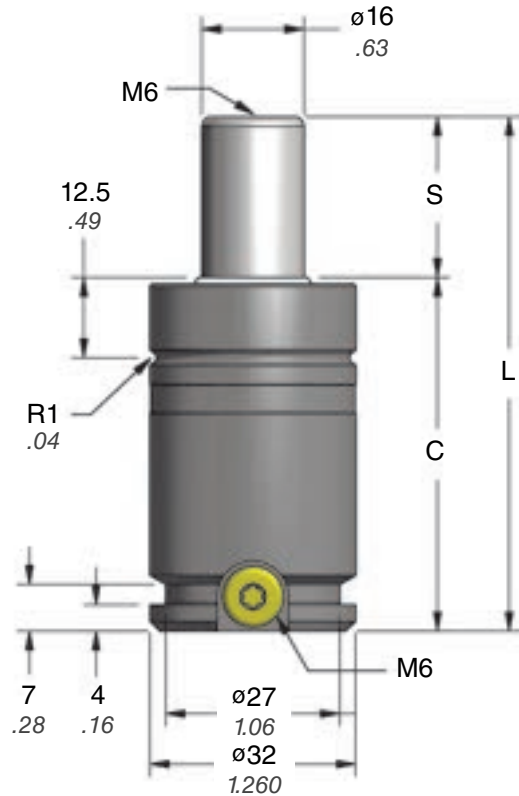

TO - Basic Model

Part No.	S mm inch	C	L ±0.25 ±0.010
U.0400.010	10 0.39	40 1.57	50 1.969
• U.0400.013	12.5 0.49	42.5 1.67	55 2.165
U.0400.015	15 0.59	45 1.77	60 2.362
U.0400.016	16 0.63	46 1.81	62 2.441
U.0400.019	19 0.75	49 1.93	68 2.677
• U.0400.025	25 0.98	55 2.17	80 3.150
U.0400.032	32 1.26	62 2.44	94 3.701
• U.0400.038	37.5 1.48	67.5 2.66	105 4.134
• U.0400.050	50 1.97	80 3.15	130 5.118
U.0400.063	62.5 2.46	92.5 3.64	155 6.102
U.0400.075	75 2.95	105 4.13	180 7.087
• U.0400.080	80 3.15	110 4.33	190 7.480
U.0400.100	100 3.94	130 5.12	230 9.055
U.0400.125	125 4.92	155 6.10	280 11.024

• Preferred Sizes

Ordering Example:

U.0400.025. TO. C. 180

Part Number:

Includes Series, Model and Stroke Length.

Mount Option:

TO = Basic Model. When not specified, default is TO.
B319V, B21 and B25 mounts ordered with cylinder will be attached at the factory.

Charging Pressure:

15–180 bar (220–2600 psi).
When not specified, default is 180 bar.

Operating System: C = Self-contained,
F = Open Flow Fitting. When not specified, default is C, self-contained.

U.0400 — 362 daN / 0.4 ton

U.0400 Force Charts

On-Contact Force

psi	lb.
2600	810
2175	678
2000	623
1750	545
1500	467
1000	312
500	156
250	78

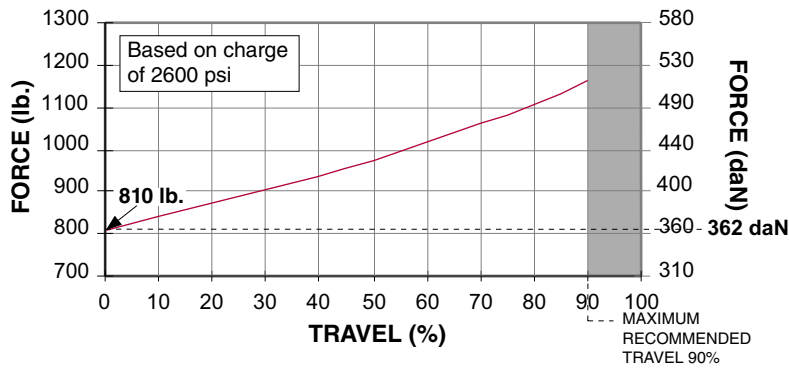

On-Contact Force

bar	daN
180	362
150	302
125	251
100	201
75	151
50	101
25	50
20	40

Mount Options

B12 **90.12.0400**

B319V **90.319V.0400**

2 x M8x50 mm SHCS SUPPLIED *Replaces 90.319 Mount, contact DADCO.*

SLIDE MOUNT INTO DESIRED LOCATION AND SECURE USING THE TWO SHCS PROVIDED

B21 **C250-RF**

ø50 BOLT CIRCLE 1.969

Split Wire Ring Included 90.55.250

SECURE MOUNT ONTO TOP GROOVE WITH SUPPLIED RING AND SCREWS

B25 **90.25.0400**

Split Wire Ring Included 90.55.250

SECURE MOUNT ONTO TOP GROOVE WITH SUPPLIED RING AND SCREWS

Ordering Example: **Cylinder with Mount:** U.0400.025.B12.C.180 **Mount Only:** 90.12.0400

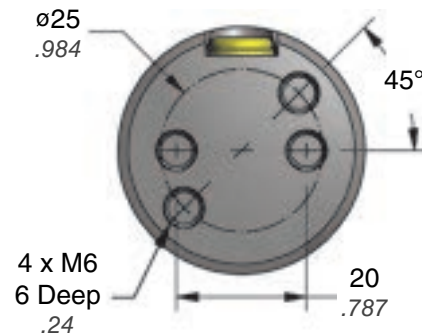
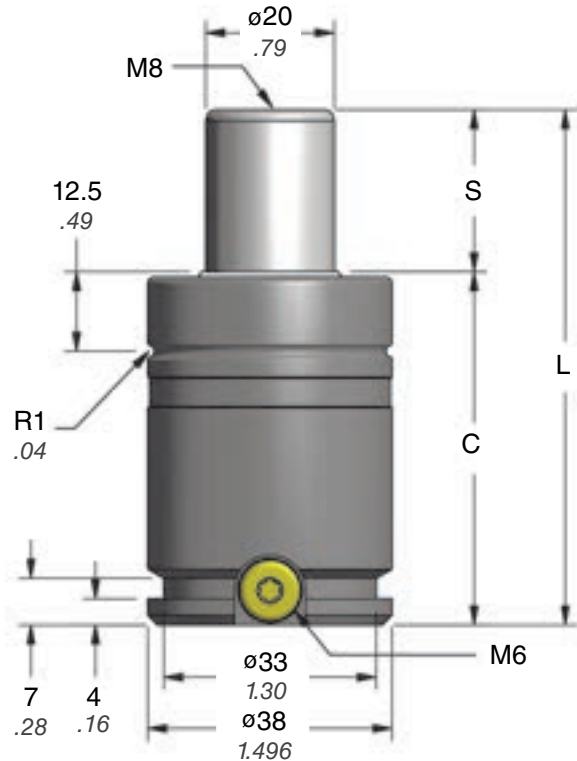

TO - Basic Model
(for new designs)

Part No.	S mm inch	C	L ±0.25 ±0.010
U.0600.010	10 0.39	40 1.57	50 1.969
• U.0600.013	12.5 0.49	42.5 1.67	55 2.165
U.0600.015	15 0.59	45 1.77	60 2.362
U.0600.016	16 0.63	46 1.81	62 2.441
U.0600.019	19 0.75	49 1.93	68 2.677
• U.0600.025	25 0.98	55 2.17	80 3.150
U.0600.032	32 1.26	62 2.44	94 3.701
• U.0600.038	37.5 1.48	67.5 2.66	105 4.134
• U.0600.050	50 1.97	80 3.15	130 5.118
U.0600.063	62.5 2.46	92.5 3.64	155 6.102
U.0600.075	75 2.95	105 4.13	180 7.087
• U.0600.080	80 3.15	110 4.33	190 7.480
U.0600.100	100 3.94	130 5.12	230 9.055
U.0600.125	125 4.92	155 6.10	280 11.024

• Preferred Sizes

Ordering Example:

U.0600.025. TO. C. 150

Part Number:

Includes Series, Model and Stroke Length.

Mount Option:

TO = Basic Model, TP = Previous Model. *When not specified, default is TO.* B319V, B21 and B25 mounts ordered with cylinder will be attached at the factory.

Charging Pressure:

15–150 bar (220–2175 psi).

When not specified, default is 150 bar.

Operating System: C = Self-contained, F = Open Flow Fitting. *When not specified, default is C, self-contained.*

U.0600 — 471 daN / 0.5 ton

U.0600 Force Charts

On-Contact Force

psi	lb.
2175	1059
2000	974
1750	852
1500	730
1000	487
500	243
250	122

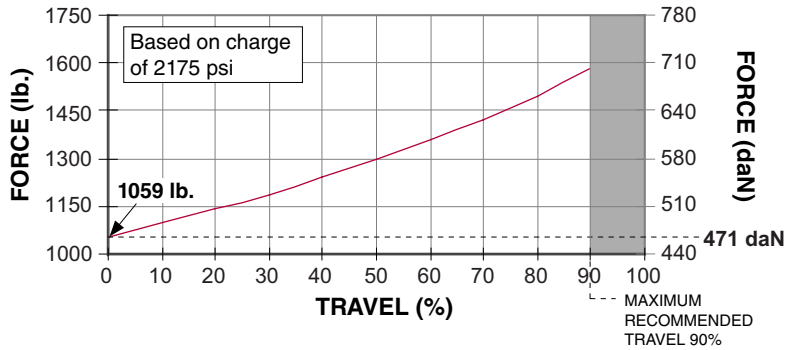

On-Contact Force

bar	daN
150	471
125	393
100	314
75	236
50	157
25	79
20	63

Mount Options

B312 **90.312.00300**

4 x M6 SHCS
1/4 SHCS

B319V **90.319V.0600**

2 x M8x50 mm SHCS SUPPLIED

SLIDE MOUNT INTO DESIRED LOCATION AND SECURE USING THE TWO SHCS PROVIDED

B21 **90.21.00300**

ø56 BOLT CIRCLE
2.205

4 x M6 SHCS
1/4 SHCS

Split Wire Ring Included
90.55.3.300

SECURE MOUNT ONTO TOP GROOVE WITH SUPPLIED RING AND SCREWS

B25 **90.25.00300**

4 x M6 SHCS
1/4 SHCS

Split Wire Ring Included
90.55.3.300

SECURE MOUNT ONTO TOP GROOVE WITH SUPPLIED RING AND SCREWS

Ordering Example:

Cylinder with Mount: U.0600.025.B312.C.150

Mount Only: 90.312.00300

Ultra Force® Nitrogen Gas Springs

U.0800 — 736 daN / 0.7 ton

Refer to Catalog C16115B for VDI conforming model, U.0845VS.

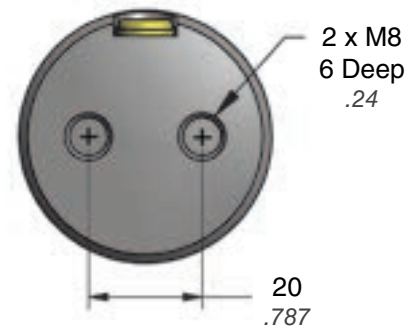
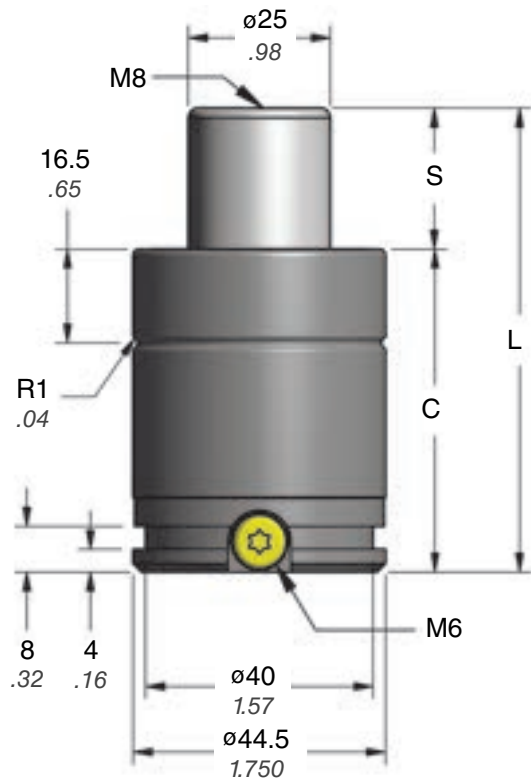

TO - Basic Model

Part No.	S mm inch	C	L ±0.25 ±0.010
U.0800.010	10 0.39	42 1.65	52 2.047
• U.0800.013	12.5 0.49	44.5 1.75	57 2.244
U.0800.016	16 0.63	48 1.89	64 2.520
U.0800.019	19 0.75	51 2.01	70 2.756
• U.0800.025	24.8 0.98	56.8 2.24	81.6 3.213
U.0800.032	32 1.26	64 2.52	96 3.780
• U.0800.038	37.5 1.48	69.5 2.74	107 4.213
• U.0800.050	50 1.97	82 3.23	132 5.197
U.0800.063	62.5 2.46	94.5 3.72	157 6.181
U.0800.075	75 2.95	107 4.21	182 7.165
• U.0800.080	80 3.15	112 4.41	192 7.559
U.0800.100	100 3.94	132 5.20	232 9.134
U.0800.125	125 4.92	157 6.18	282 11.102

• Preferred Sizes

Ordering Example:

U.0800.025. TO. C. 150

Part Number:

Includes Series, Model and Stroke Length.

Mount Option:

TO = Basic Model. When not specified, default is TO.

B319V, B21 and B25 mounts ordered with cylinder will be attached at the factory.

Charging Pressure:

15–150 bar (220–2175 psi).

When not specified, default is 150 bar.

Operating System: C = Self-contained, F = Open Flow Fitting. When not specified, default is C, self-contained.

U.0800 — 736 daN / 0.7 ton

U.0800 Force Charts

On-Contact Force

psi	lb.
2175	1655
2000	1522
1750	1331
1500	1141
1000	761
500	380
250	190

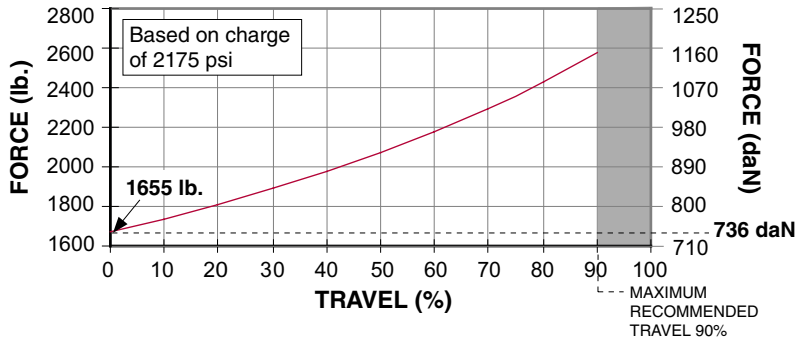

On-Contact Force

bar	daN
150	736
125	614
100	491
75	368
50	245
25	123
20	98

Mount Options

B312 **90.312.00500**

□70
2.76

□50
1.968

4 x M8 SHCS
5/16 SHCS

7
.28

B319V **90.319V.0800**

2 x M8x50 mm SHCS SUPPLIED

80
3.15

60
2.362

10
.39

27.5
1.08

20
.79

22
.87

60
2.36

SLIDE MOUNT INTO DESIRED LOCATION AND SECURE USING THE TWO SHCS PROVIDED

B21 **90.21.00500**

ø86
3.39

ø70.7 BOLT CIRCLE
2.783

4 x M8 SHCS
5/16 SHCS

□50
1.968

13
.51

23
.91

Split Wire Ring Included
90.55.3.500

SECURE MOUNT ONTO TOP GROOVE WITH SUPPLIED RING AND SCREWS

B25 **90.25.00500**

4 x M8 SHCS
5/16 SHCS

□50
1.968

□64
2.52

13
.51

23
.91

Split Wire Ring Included
90.55.3.500

SECURE MOUNT ONTO TOP GROOVE WITH SUPPLIED RING AND SCREWS

Ordering Example:

Cylinder with Mount: U.0800.025.B312.C.150

Mount Only: 90.312.00500

Ultra Force® Nitrogen Gas Springs

U.1000 — 10 kN / 1.0 ton

For 15% more force in the same diameter body and length refer to the U.1200 on page 16.

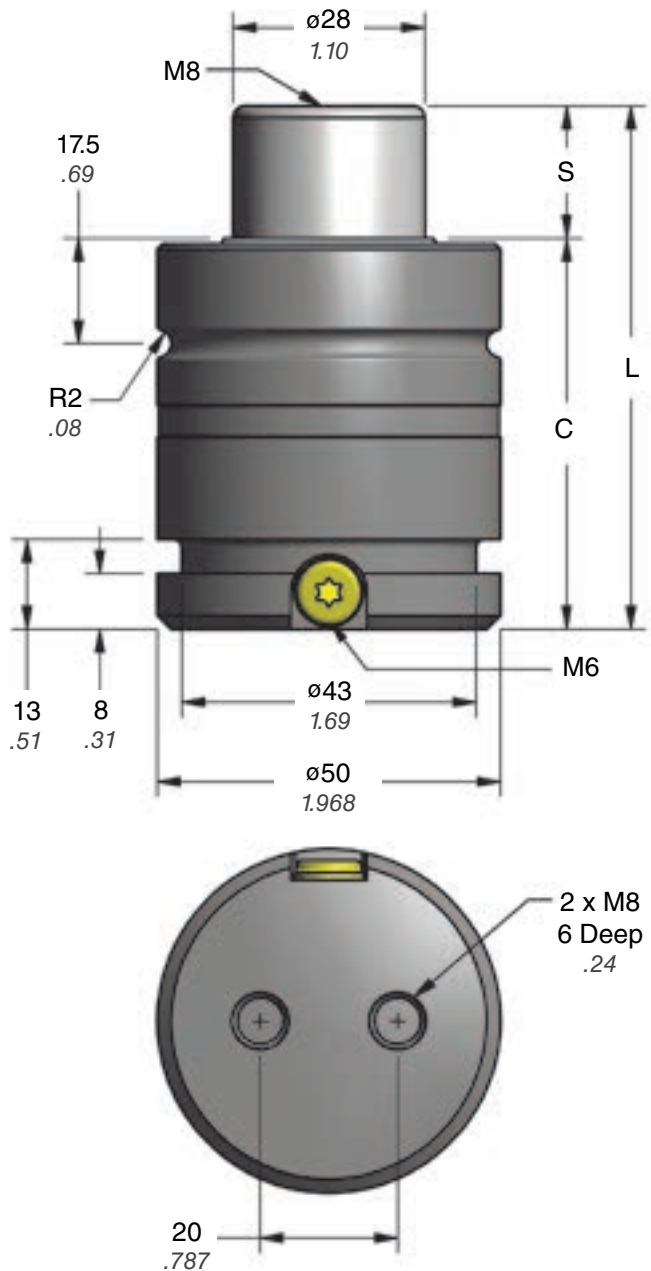

Part No.	S mm inch	C	L ± 0.25 ± 0.010
• U.1000.013	12.5 0.49	50.5 1.99	63 2.480
U.1000.016	16 0.63	54 2.13	70 2.756
U.1000.019	19 0.75	57 2.24	76 2.992
• U.1000.025	25 0.98	63 2.48	88 3.465
U.1000.032	32 1.26	70 2.76	102 4.016
• U.1000.038	37.5 1.48	75.5 2.97	113 4.449
• U.1000.050	50 1.97	88 3.46	138 5.433
U.1000.063	62.5 2.46	100.5 3.96	163 6.417
U.1000.075	75 2.95	113 4.45	188 7.402
• U.1000.080	80 3.15	118 4.65	198 7.795
U.1000.100	100 3.94	138 5.43	238 9.370
U.1000.125	125 4.92	163 6.42	288 11.339

• Preferred Sizes

TO - Basic Model

Ordering Example:

U.1000.025. TO. C. 150

Part Number: _____

Includes Series, Model and Stroke Length.

Mount Option: _____

TO = Basic Model. When not specified, default is TO.
B319V, B21 and B25 mounts ordered with cylinder will be attached at the factory.

Charging Pressure:

15–150 bar (220–2175 psi).

When not specified, default is 150 bar.

Operating System: C = Self-contained,
F = Open Flow Fitting. When not specified, default is C, self-contained.

U.1000 — 10 kN / 1.0 ton

U.1000 Force Charts

On-Contact Force

psi	lb.
2175	2076
2000	1909
1750	1670
1500	1432
1000	954
500	477
250	239

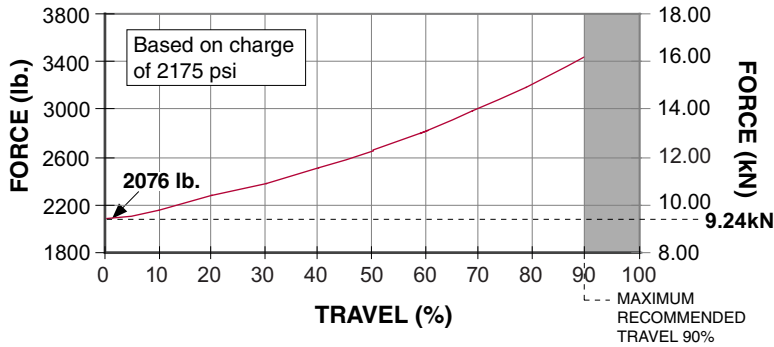

On-Contact Force

bar	kN
150	9.24
125	7.70
100	6.16
75	4.62
50	3.08
25	1.54
20	1.23

Mount Options

B12 **90.12.00750**

4 x M8 SHCS
5/16 SHCS

B319V **90.319V.1000**

90.19 Mount, see page 30.

2 x M10x60 mm SHCS SUPPLIED

SLIDE MOUNT INTO DESIRED LOCATION AND SECURE USING THE TWO SHCS PROVIDED

B21 **90.21.00750**

ø80 BOLT CIRCLE 3.150

4 x M8 SHCS 5/16 SHCS

Split Wire Ring Included 90.55.10.750

SECURE MOUNT ONTO TOP GROOVE WITH SUPPLIED RING AND SCREWS

B25 **90.25.00750**

4 x M8 SHCS 5/16 SHCS

Split Wire Ring Included 90.55.10.750

SECURE MOUNT ONTO TOP GROOVE WITH SUPPLIED RING AND SCREWS

Ordering Example:

Cylinder with Mount: U.1000.025.B12.C.150

Mount Only: 90.12.00750

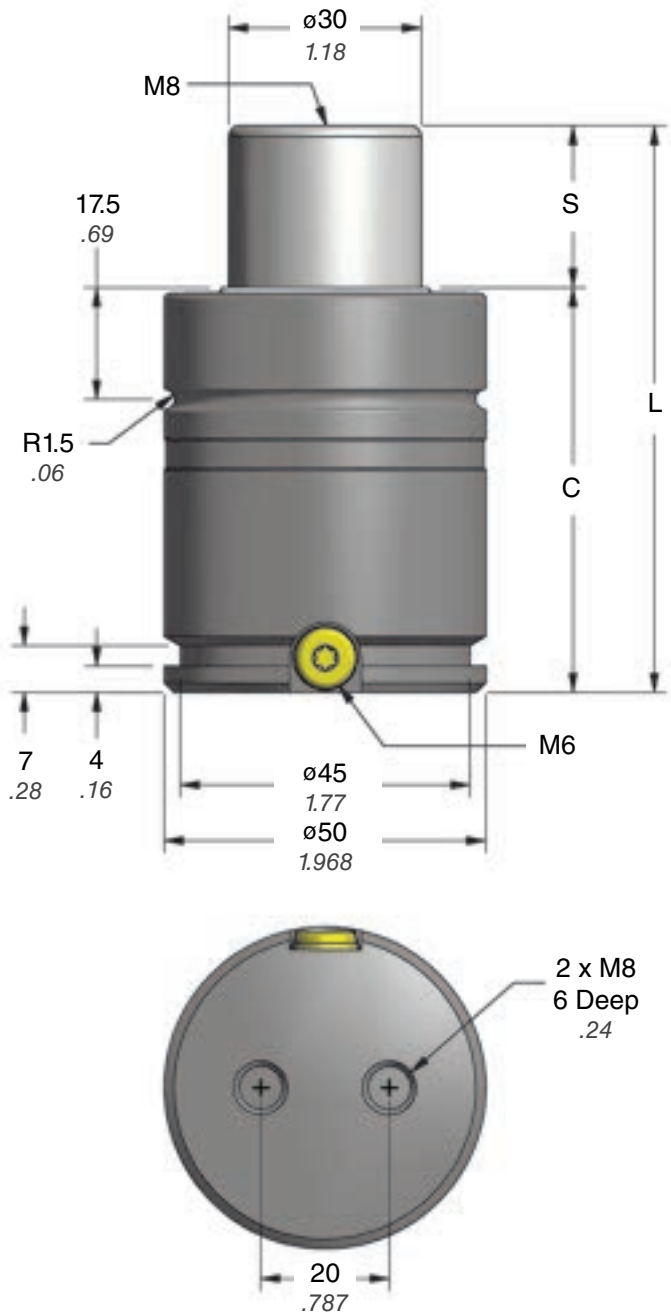

TO - Basic Model

Part No.	S mm inch	C	L ±0.25 ±0.010
U.1200.010	10 0.39	48 1.89	58 2.283
• U.1200.013	12.5 0.49	50.5 1.99	63 2.480
U.1200.015	15 0.59	53 2.09	68 2.677
U.1200.019	19 0.75	57 2.24	76 2.992
• U.1200.025	25 0.98	63 2.48	88 3.465
U.1200.032	32 1.26	70 2.76	102 4.016
• U.1200.038	37.5 1.48	75.5 2.97	113 4.449
• U.1200.050	50 1.97	88 3.46	138 5.433
U.1200.063	62.5 2.46	100.5 3.96	163 6.417
U.1200.075	75 2.95	113 4.45	188 7.402
• U.1200.080	80 3.15	118 4.65	198 7.795
U.1200.100	100 3.94	138 5.43	238 9.370
U.1200.125	125 4.92	163 6.42	288 11.339

• Preferred Sizes

Ordering Example:

U.1200.025. TO. C. 150

Part Number:

Includes Series, Model and Stroke Length.

Mount Option:

TO = Basic Model. *When not specified, default is TO.*
 B319V, B321 and B322 mounts ordered with cylinder will be attached at the factory.

Charging Pressure:

15–150 bar (220–2175 psi).
When not specified, default is 150 bar.

Operating System: C = Self-contained,
 F = Open Flow Fitting. *When not specified, default is C, self-contained.*

U.1200 — 10.5 kN / 1.2 ton

U.1200 Force Charts

On-Contact Force

psi	lb.
2175	2383
2000	2191
1750	1917
1500	1643
1000	1096
500	548
250	274

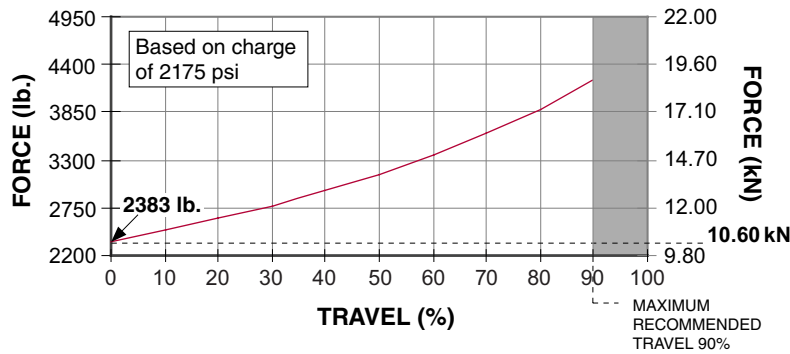

On-Contact Force

bar	kN
150	10.60
125	8.84
100	7.07
75	5.30
50	3.53
25	1.77
20	1.41

Mount Options

B312 **90.312.00750**

B319V **90.319V.1000**

2 x M10x60 mm SHCS SUPPLIED

90.19 Mount, see page 30.

SLIDE MOUNT INTO DESIRED LOCATION AND SECURE USING THE TWO SHCS PROVIDED

B322 **90.322.00750**

B321 **90.321.00750**

SECURE MOUNT ONTO TOP GROOVE WITH SUPPLIED RING AND SCREWS

Ordering Example:

Cylinder with Mount: U.1200.025.B312.C.150

Mount Only: 90.312.00750

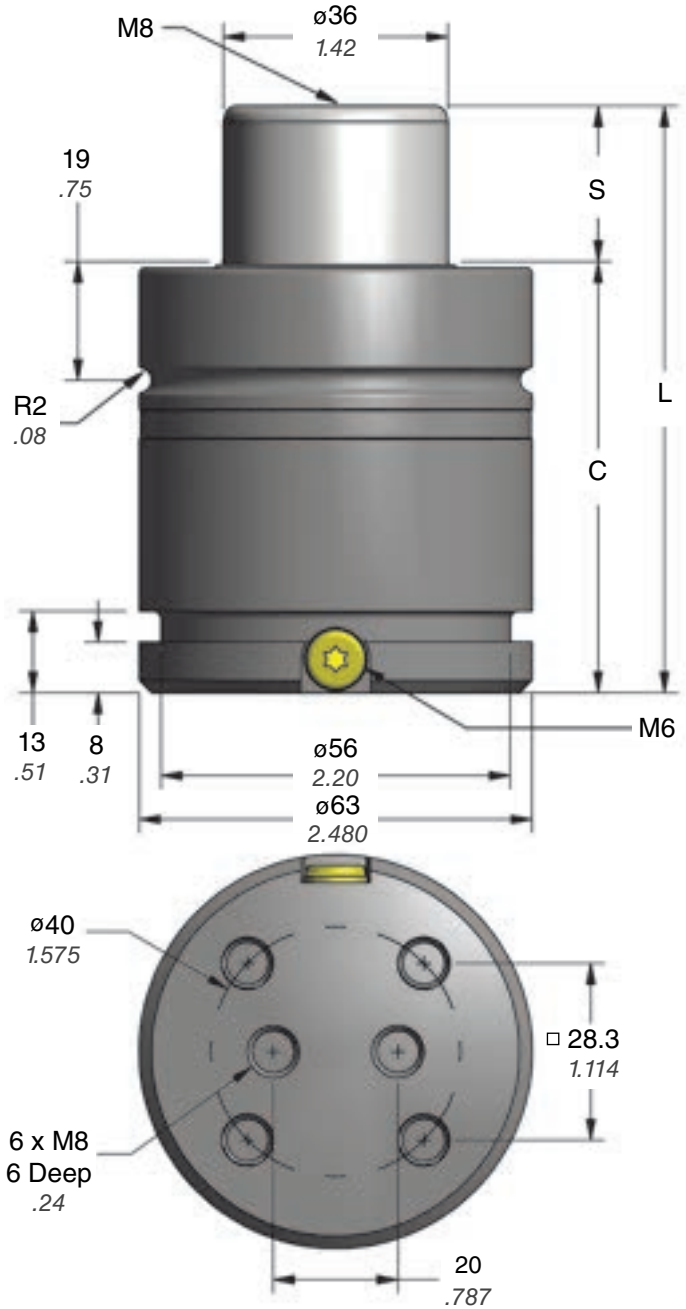

Part No.	S mm inch	C	L ±0.25 ±0.010
U.1600.010	10 0.39	54 2.13	64 2.520
• U.1600.013	12.5 0.49	56.5 2.22	69 2.717
U.1600.015	15 0.59	59 2.32	74 2.915
U.1600.016	16 0.63	60 2.36	76 2.992
U.1600.019	19 0.75	63 2.48	82 3.228
• U.1600.025	25 0.98	69 2.72	94 3.701
U.1600.032	32 1.26	76 2.99	108 4.252
• U.1600.038	37.5 1.48	81.5 3.21	119 4.685
• U.1600.050	50 1.97	94 3.70	144 5.669
U.1600.063	62.5 2.46	106.5 4.19	169 6.654
U.1600.075	75 2.95	119 4.69	194 7.638
• U.1600.080	80 3.15	124 4.88	204 8.031
U.1600.100	100 3.94	144 5.67	244 9.606
U.1600.125	125 4.92	169 6.65	294 11.575

• Preferred Sizes

AO - Basic Model

*For base mounting secure with a minimum of 4 fasteners.

Ordering Example:

U.1600.025. AO. C. 150

Part Number:

Includes Series, Model and Stroke Length.

Mount Option:

AO = Basic Model. When not specified, default is AO.

B319V, B21, B25 and B325 mounts ordered with cylinder will be attached at the factory.

Charging Pressure:

15–150 bar (220–2175 psi).

When not specified, default is 150 bar.

Operating System: C = Self-contained, F = Open Flow Fitting. When not specified, default is C, self-contained.

U.1600 — 15 kN / 1.7 ton

U.1600 Force Charts

On-Contact Force

psi	lb.
2175	3432
2000	3155
1750	2761
1500	2367
1000	1578
500	789
250	394

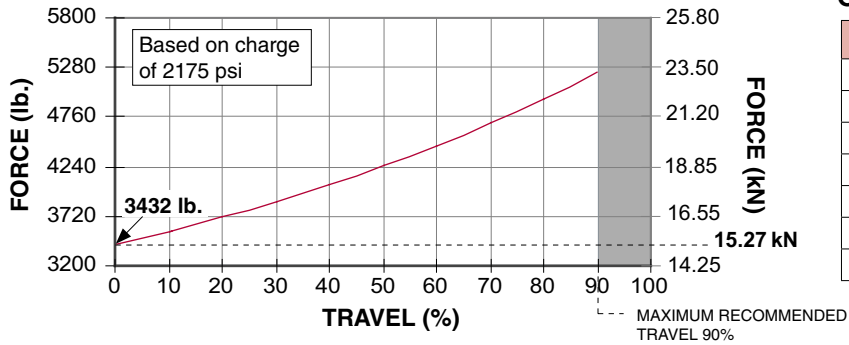

On-Contact Force

bar	kN
150	15.27
125	12.72
100	10.18
75	7.63
50	5.09
25	2.54
20	2.04

Mount Options

B112 / 90.112.1600

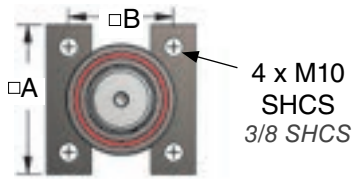

Part No.	A	B
90.112.1600	85 (3.35)	60 (2.362)
90.212.1600	100 (3.94)	73.5 (2.894)



B212 / 90.212.1600

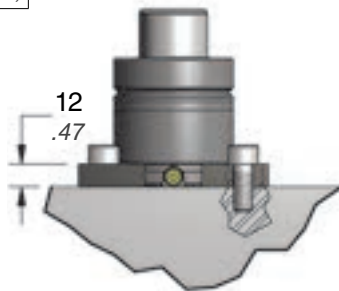
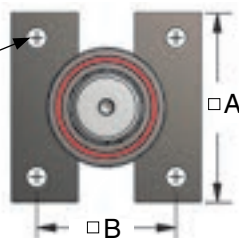

B319V

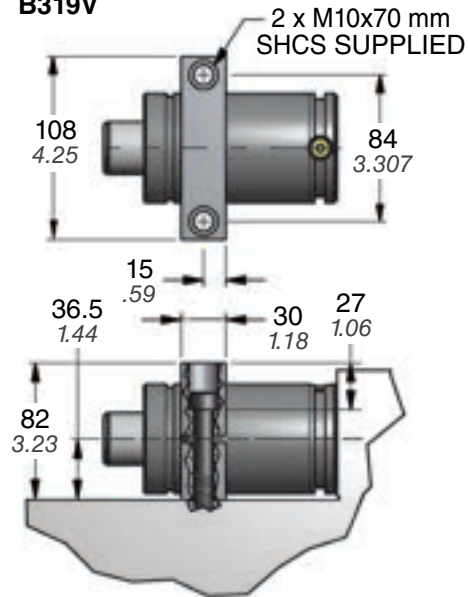

90.319V.1600



SLIDE MOUNT INTO DESIRED LOCATION AND SECURE USING THE TWO SHCS PROVIDED

B21

90.21.1600

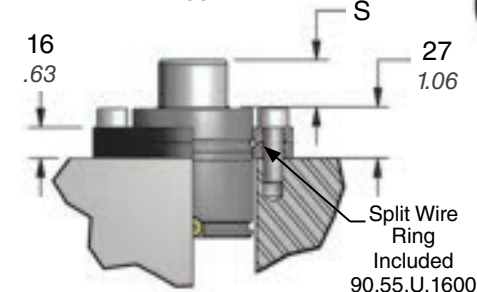
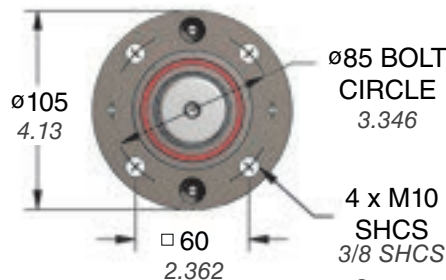

B325 / B25

90.325.1600 / 90.25.1600

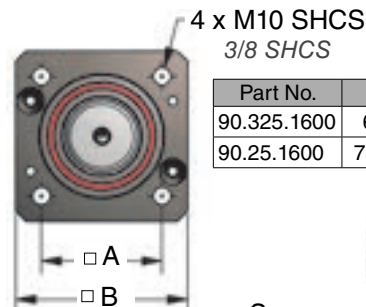

Part No.	A	B
90.325.1600	64 (2.520)	80 (3.150)
90.25.1600	73.5 (2.894)	90 (3.54)

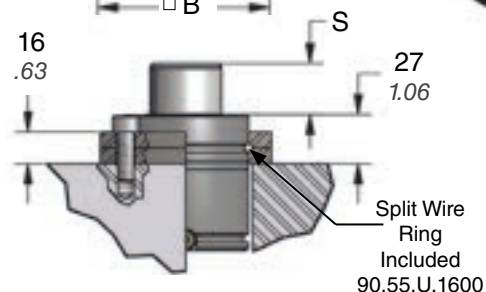

Ordering Example:

Cylinder with Mount: U.1600.025.B112.C.150

Mount Only: 90.112.1600

Ultra Force® Nitrogen Gas Springs

U.2600 — 24 kN / 2.6 ton

Refer to Catalog C16115B for VDI conforming model, U.2600VS.

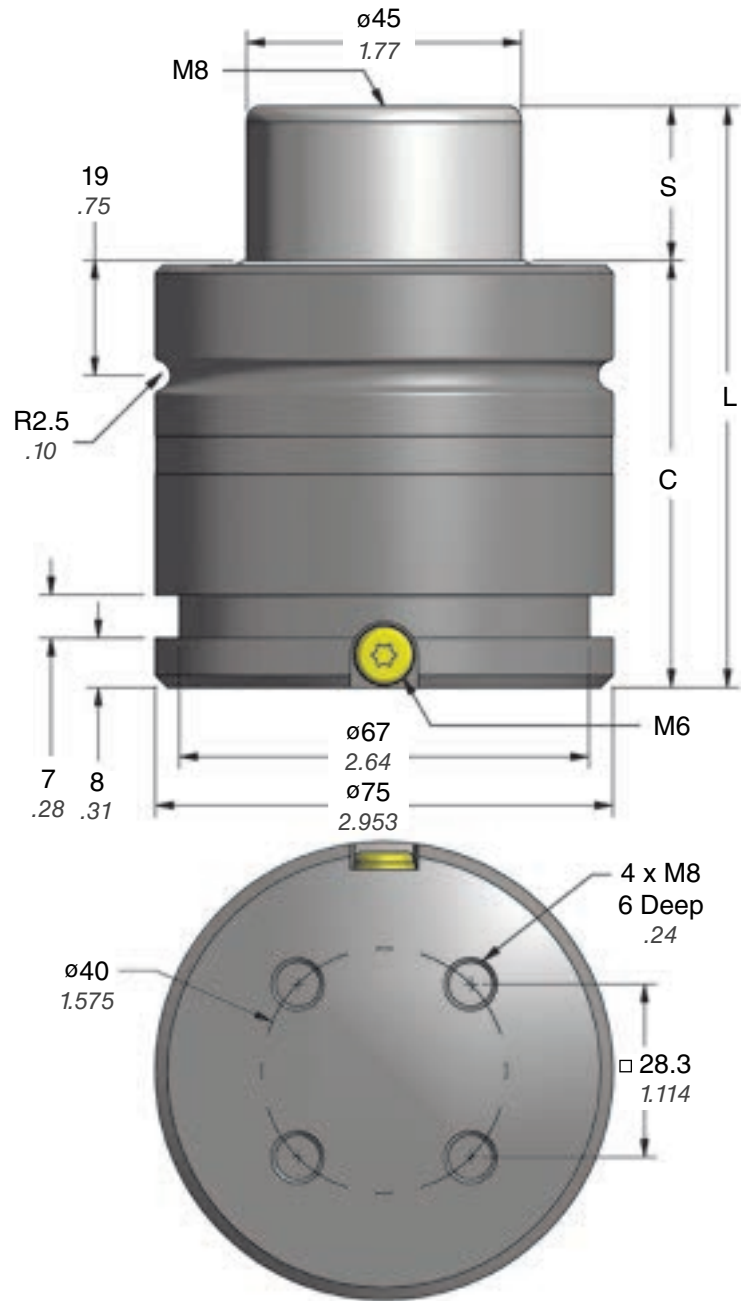

TO - Basic Model

Part No.	S mm inch	C	L ±0.25 ±0.010
U.2600.016	16 0.63	61 2.40	77 3.031
U.2600.019	19 0.75	64 2.52	83 3.268
• U.2600.025	25 0.98	70 2.76	95 3.740
U.2600.032	32 1.26	77 3.03	109 4.291
• U.2600.038	37.5 1.48	82.5 3.25	120 4.724
• U.2600.050	50 1.97	95 3.74	145 5.709
U.2600.063	62.5 2.46	107.5 4.23	170 6.693
U.2600.075	75 2.95	120 4.72	195 7.677
• U.2600.080	80 3.15	125 4.92	205 8.071
U.2600.100	100 3.94	145 5.71	245 9.646
U.2600.125	125 4.92	170 6.69	295 11.614

• Preferred Sizes

Ordering Example:

U.2600.025. TO. C. 150

Part Number:

Includes Series, Model and Stroke Length.

Mount Option:

TO = Basic Model. When not specified, default is TO.

B319V, B21, B25 and B325 mounts ordered with cylinder will be attached at the factory.

Charging Pressure:

15–150 bar (220–2175 psi).

When not specified, default is 150 bar.

Operating System: C = Self-contained, F = Open Flow Fitting. When not specified, default is C, self-contained.

U.2600 — 24 kN / 2.6 ton

U.2600 Force Charts

On-Contact Force

psi	lb.
2175	5362
2000	4930
1750	4314
1500	3698
1000	2465
500	1233
250	616

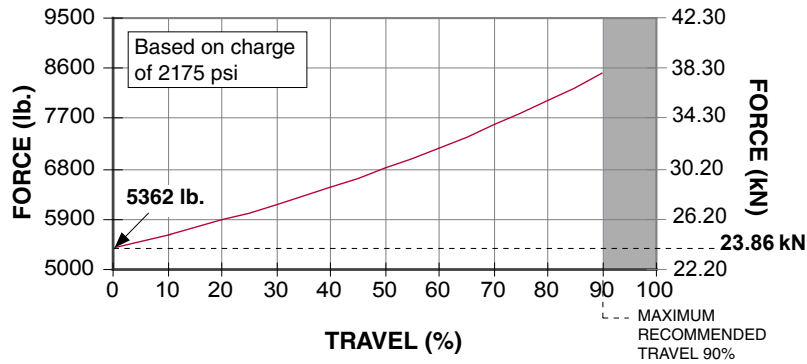

On-Contact Force

bar	kN
150	23.86
125	19.88
100	15.90
75	11.93
50	7.95
25	3.98
20	3.18

Mount Options

B12 **90.12.01500**

4 x M10 SHCS 3/8 SHCS

B319V

2 x M12x80 mm SHCS SUPPLIED

90.19 Mount, see page 30.

SLIDE MOUNT INTO DESIRED LOCATION AND SECURE USING THE TWO SHCS PROVIDED

B21 **90.21.01500**

4 x M10 SHCS 3/8 SHCS

Split Wire Ring Included 90.55.1500

SECURE MOUNT ONTO TOP GROOVE WITH SUPPLIED RING AND SCREWS

B325 / B25 **90.325.2600 / 90.25.01500**

Part No.	A	B	E
90.325.2600	16 (.63)	10 (.39)	29 (1.14)
90.25.01500	16 (.63)	8 (.315)	27 (1.06)

Split Wire Ring Included 90.55.1500

SECURE MOUNT ONTO TOP GROOVE WITH SUPPLIED RING AND SCREWS

Ordering Example:

Cylinder with Mount: U.2600.025.B12.C.150

Mount Only: 90.12.01500

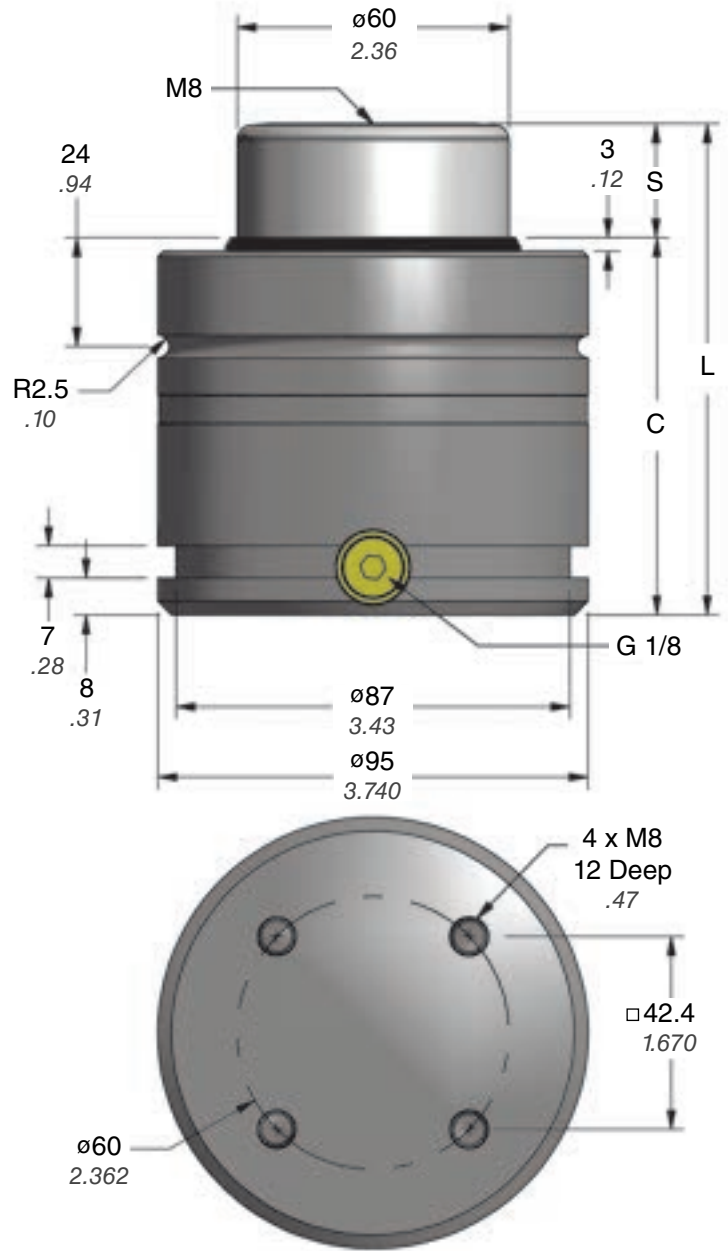

TO - Basic Model

Part No.	S mm inch	C	L ± 0.25 ± 0.010
U.4600.016	16 0.63	74 2.91	90 3.543
U.4600.019	19 0.75	77 3.03	96 3.780
• U.4600.025	25 0.98	83 3.27	108 4.252
U.4600.032	32 1.26	90 3.54	122 4.803
• U.4600.038	37.5 1.48	95.5 3.76	133 5.236
• U.4600.050	50 1.97	108 4.25	158 6.220
U.4600.063	62.5 2.46	120.5 4.74	183 7.205
U.4600.075	75 2.95	133 5.24	208 8.189
• U.4600.080	80 3.15	138 5.43	218 8.583
U.4600.100	100 3.94	158 6.22	258 10.157
U.4600.125	125 4.92	183 7.20	308 12.126

• Preferred Sizes

Ordering Example:

U.4600.025. TO. C. 150

Part Number:

Includes Series, Model and Stroke Length.

Mount Option:

TO = Basic Model. When not specified, default is TO.

B319V, B21 and B25 mounts ordered with cylinder will be attached at the factory.

Charging Pressure:

15–150 bar (220–2175 psi).

When not specified, default is 150 bar.

Operating System: C = Self-contained, F = Open Flow Fitting. When not specified, default is C, self-contained.

U.4600 — 42 kN / 4.7 ton

U.4600 Force Charts

On-Contact Force

psi	lb.
2175	9532
2000	8765
1750	7669
1500	6574
1000	4383
500	2191
250	1096

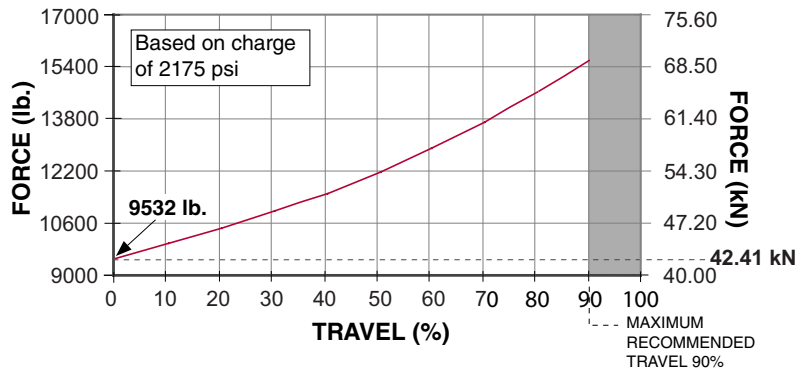

On-Contact Force

bar	kN
150	42.41
125	35.34
100	28.27
75	21.21
50	14.14
25	7.07
20	5.65

Mount Options

B12 **90.12.03000**

4 x M12 SHCS
1/2 SHCS

12
.47

B319V **90.319V.4600**

2 x M12x100 mm SHCS SUPPLIED

90.19 Mount, see page 30.

SLIDE MOUNT INTO DESIRED LOCATION AND SECURE USING THE TWO SHCS PROVIDED

B21 **90.21.03000**

ø130 BOLT CIRCLE
5.118

4 x M12 SHCS
1/2 SHCS

18
.71

33
1.30

Split Wire Ring Included
90.55.3000

SECURE MOUNT ONTO TOP GROOVE WITH SUPPLIED RING AND SCREWS

B25 **90.25.03000**

4 x M12 SHCS
1/2 SHCS

18
.71

33
1.30

Split Wire Ring Included
90.55.3000

SECURE MOUNT ONTO TOP GROOVE WITH SUPPLIED RING AND SCREWS

Ordering Example:

Cylinder with Mount: U.4600.025.B12.C.150

Mount Only: 90.12.03000

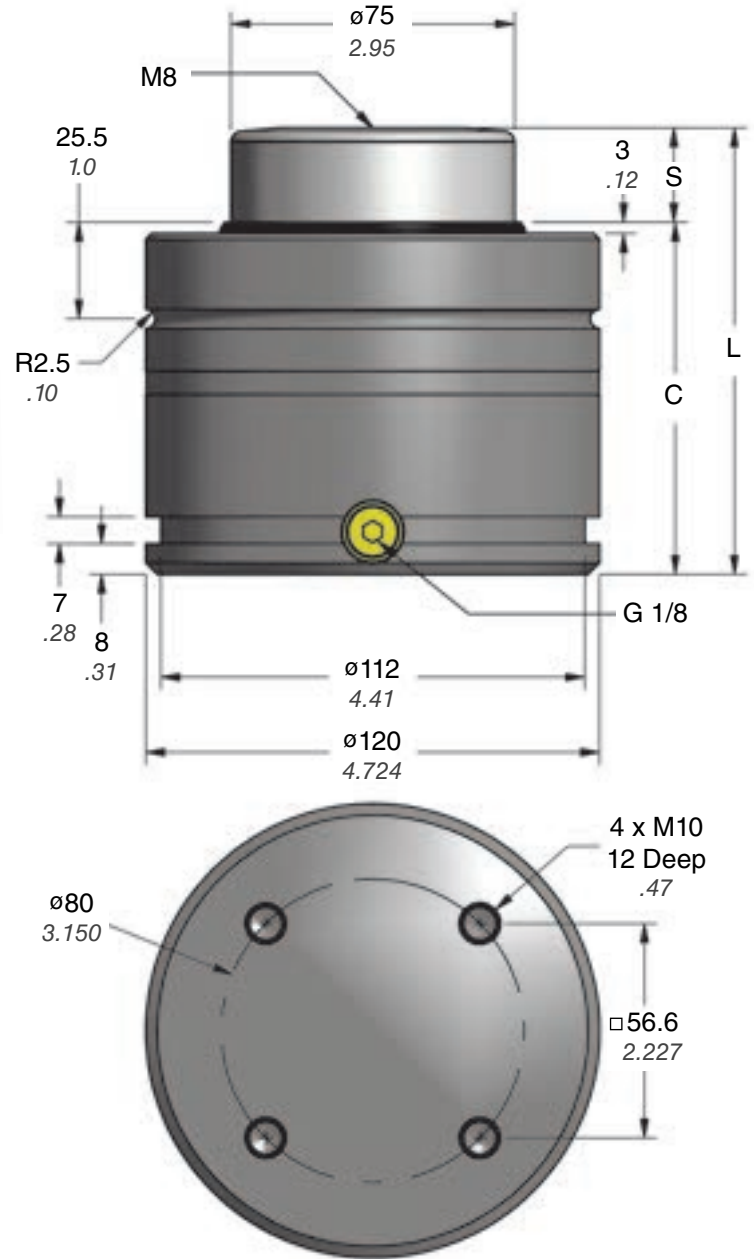

TO - Basic Model

Part No.	S mm inch	C	L ±0.25 ±0.010
U.6600.016	16 0.63	84 3.31	100 3.937
U.6600.019	19 0.75	87 3.43	106 4.173
• U.6600.025	25 0.98	93 3.66	118 4.646
U.6600.032	32 1.26	100 3.94	132 5.197
• U.6600.038	37.5 1.48	105.5 4.15	143 5.630
• U.6600.050	50 1.97	118 4.65	168 6.614
U.6600.063	62.5 2.46	130.5 5.14	193 7.598
U.6600.075	75 2.95	143 5.63	218 8.583
• U.6600.080	80 3.15	148 5.83	228 8.976
U.6600.100	100 3.94	168 6.61	268 10.551
U.6600.125	125 4.92	193 7.60	318 12.520

• Preferred Sizes

Ordering Example:

U.6600.025. TO. C. 150

Part Number:

Includes Series, Model and Stroke Length.

Mount Option:

TO = Basic Model. When not specified, default is TO.
B319V, B21 and B25 mounts ordered with cylinder will be attached at the factory.

Charging Pressure:

15–150 bar (220–2175 psi).
When not specified, default is 150 bar.

Operating System: C = Self-contained,
F = Open Flow Fitting. When not specified, default is C, self-contained.

U.6600 — 66 kN / 7.4 ton

U.6600 Force Charts

On-Contact Force

psi	lb.
2175	14894
2000	13695
1750	11983
1500	10272
1000	6848
500	3424
250	1712

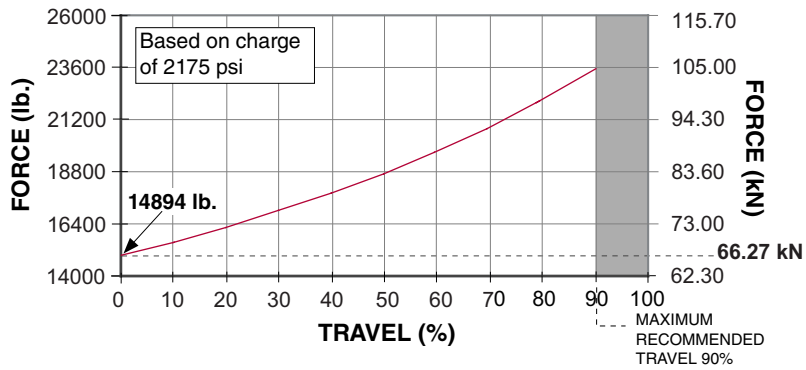

On-Contact Force

bar	kN
150	66.27
125	55.22
100	44.18
75	33.13
50	22.09
25	11.04
20	8.84

Mount Options

B12 **90.12.05000**

B319V **90.319V.6600**

2 x M12x100 mm SHCS SUPPLIED

90.19 Mount, see page 30.

SLIDE MOUNT INTO DESIRED LOCATION AND SECURE USING THE TWO SHCS PROVIDED

B21 **90.21.05000**

Secure MOUNT ONTO TOP GROOVE WITH SUPPLIED RING AND SCREWS

Split Wire Ring Included 90.55.5000

B25 **90.25.05000**

Secure MOUNT ONTO TOP GROOVE WITH SUPPLIED RING AND SCREWS

Split Wire Ring Included 90.55.5000

Ordering Example:

Cylinder with Mount: U.6600.025.B12.C.150

Mount Only: 90.12.05000

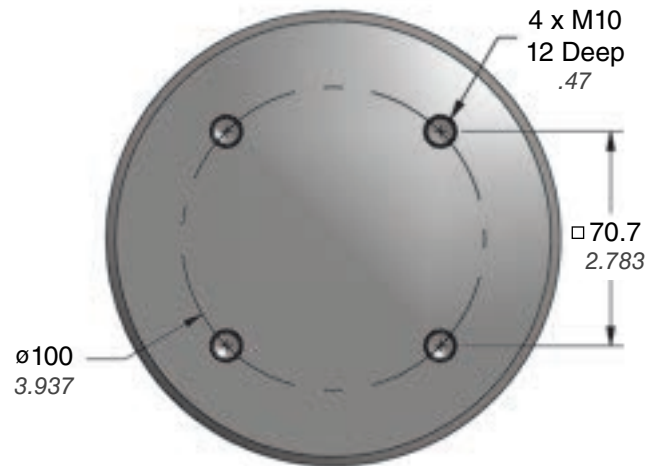
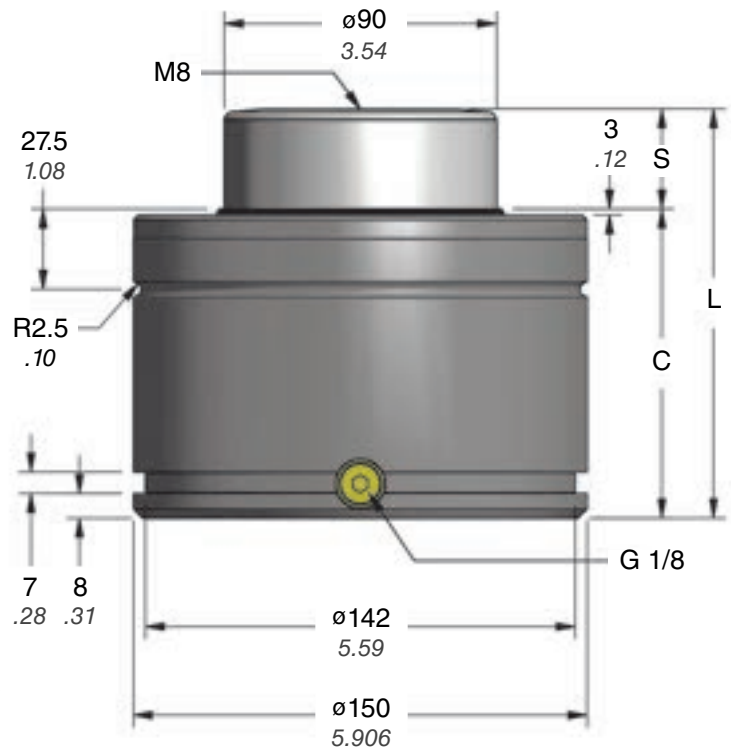

TO - Basic Model

Part No.	S mm inch	C	L ±0.25 ±0.010
U.9600.025	25 0.98	103 4.06	128 5.039
U.9600.032	32 1.26	110 4.33	142 5.591
U.9600.038	37.5 1.48	115.5 4.55	153 6.025
• U.9600.050	50 1.97	128 5.04	178 7.008
U.9600.063	62.5 2.46	140.5 5.53	203 7.992
U.9600.075	75 2.95	153 6.02	228 8.976
U.9600.080	80 3.15	158 6.22	238 9.370
U.9600.100	100 3.94	178 7.01	278 10.945
U.9600.125	125 4.92	203 7.99	328 12.913

• Preferred Sizes

Ordering Example:

U.9600.025. TO. C. 150

Part Number:

Includes Series, Model and Stroke Length.

Mount Option:

TO = Basic Model. *When not specified, default is TO.*
B319V, B21 and B25 mounts ordered with cylinder will be attached at the factory.

Charging Pressure:

15–150 bar (220–2175 psi).
When not specified, default is 150 bar.

Operating System: C = Self-contained,
F = Open Flow Fitting. *When not specified, default is C, self-contained.*

U.9600 — 95 kN / 10.7 ton

U.9600 Force Charts

On-Contact Force

psi	lb.
2175	21447
2000	19721
1750	17256
1500	14791
1000	9861
500	4930
250	2465

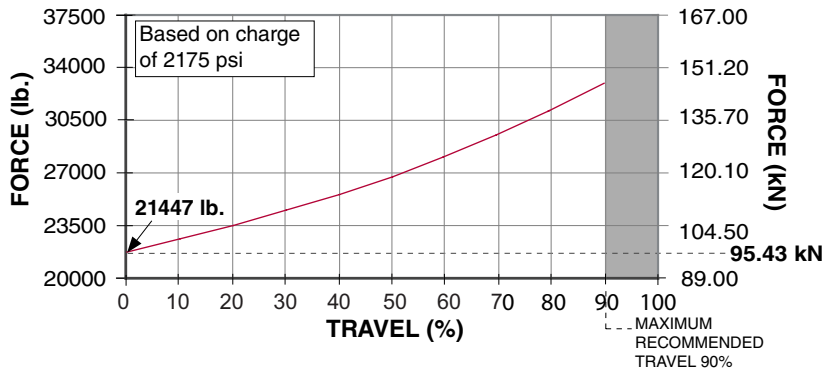

On-Contact Force

bar	kN
150	95.43
125	79.52
100	63.62
75	47.71
50	31.81
25	15.90
20	12.72

Mount Options

B12 **90.12.07500**

□190
7.48

□138
5.433

4 x M16
SHCS
5/8 SHCS

12
.47

B319V **90.319V.9600**

2 x M12x120 mm
SHCS SUPPLIED

200
7.87

175
6.890

15
.59

80
3.15

30
1.18

68
2.68

170
6.69

SLIDE MOUNT
INTO DESIRED
LOCATION AND
SECURE USING
THE TWO
SHCS PROVIDED

B21 **90.21.07500**

∅220
8.66

∅195 BOLT
CIRCLE
7.677

□138
5.433

4 x M16
SHCS
5/8 SHCS

27
1.06

S

41
1.61

Split Wire
Ring
Included
90.55.7500

SECURE MOUNT
ONTO TOP
GROOVE WITH
SUPPLIED RING
AND SCREWS

B25 **90.25.07500**

4 x M16
SHCS
5/8 SHCS

□138
5.433

□162
6.38

27
1.06

S

41
1.61

Split Wire
Ring
Included
90.55.7500

SECURE MOUNT
ONTO TOP
GROOVE WITH
SUPPLIED RING
AND SCREWS

Ordering Example:

Cylinder with Mount: U.9600.025.B12.C.150

Mount Only: 90.12.07500

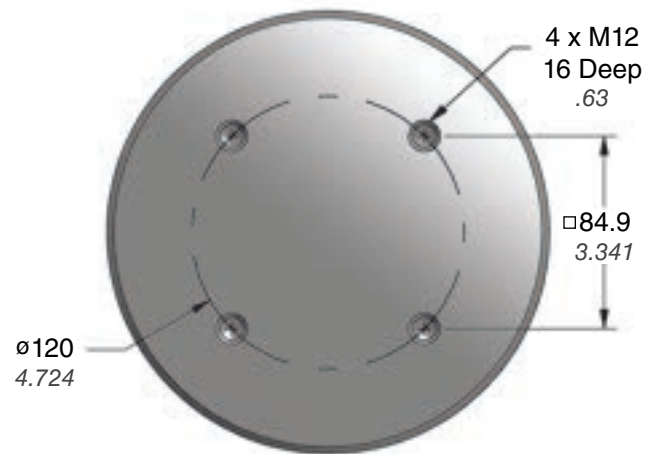
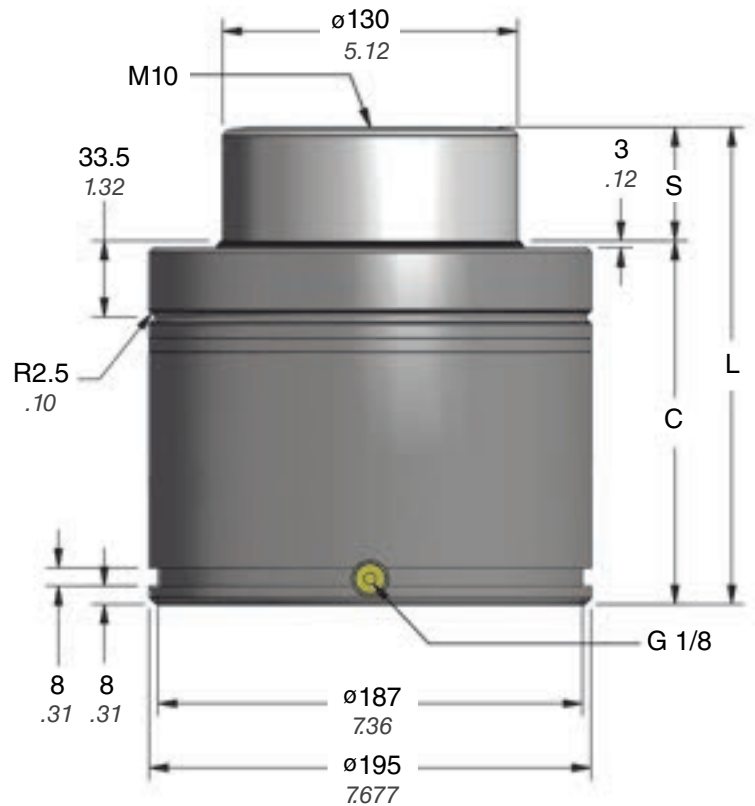

TO - Basic Model

Part No.	S mm inch	C	L ±0.25 ±0.010
U.20000.025	25 0.98	135 5.31	160 6.299
U.20000.038	37.5 1.48	147.5 5.81	185 7.283
• U.20000.050	50 1.97	160 6.30	210 8.268
U.20000.063	62.5 2.46	172.5 6.79	235 9.252
U.20000.080	80 3.15	190 7.48	270 10.630
U.20000.100	100 3.94	210 8.27	310 12.205
U.20000.125	125 4.92	235 9.25	360 14.173

• Preferred Sizes

Ordering Example:

U.20000.025. TO. C. 150

Part Number:

Includes Series, Model and Stroke Length.

Mount Option:

TO = Basic Model. When not specified, default is TO.

B19, B21 and B25 mounts ordered with cylinder will be attached at the factory.

Charging Pressure:

15–150 bar (220–2175 psi).

When not specified, default is 150 bar.

Operating System: C = Self-contained, F = Open Flow Fitting. When not specified, default is C, self-contained.

U.20000 — 199 kN / 22 ton

U.20000 Force Charts

On-Contact Force

psi	lb.
2175	44747
2000	41147
1750	36004
1500	30860
1000	20574
500	10287
250	5143

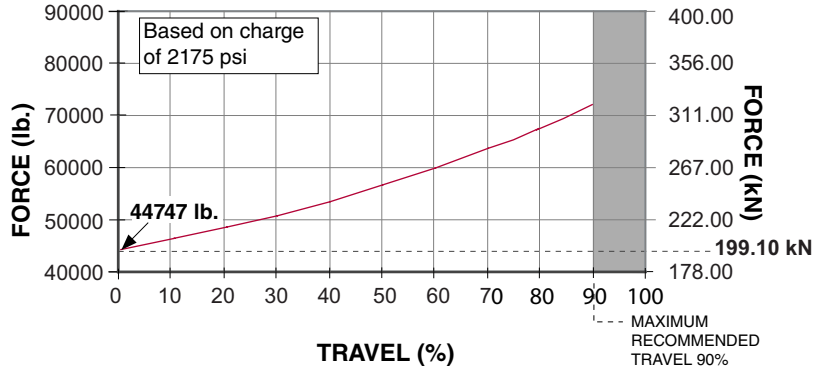

On-Contact Force

bar	kN
150	199.10
125	165.92
100	132.73
75	99.55
50	66.37
25	33.18
20	26.55

Mount Options

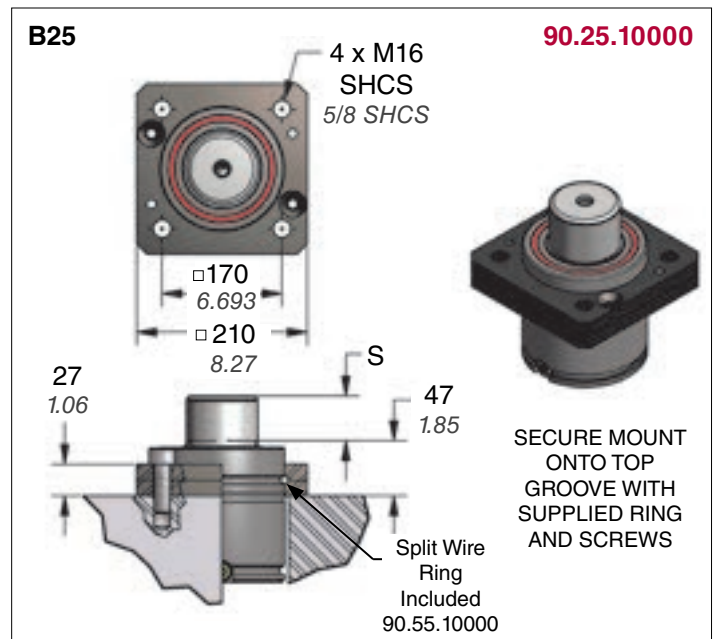
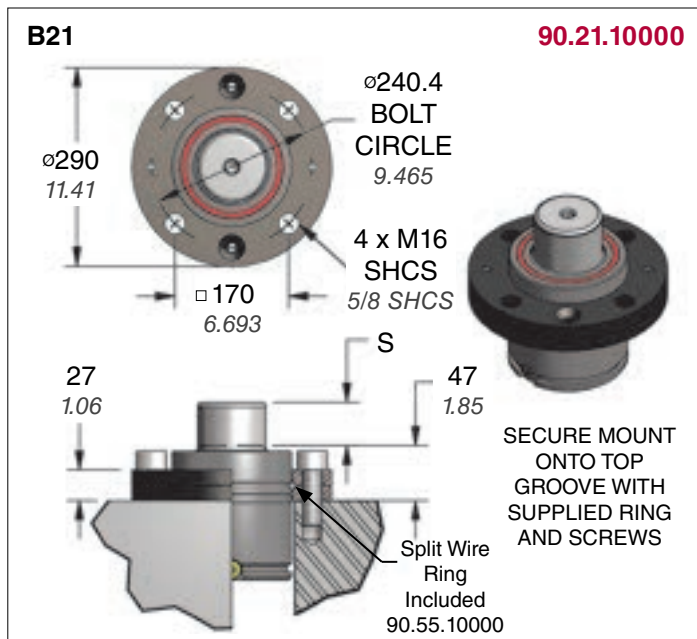
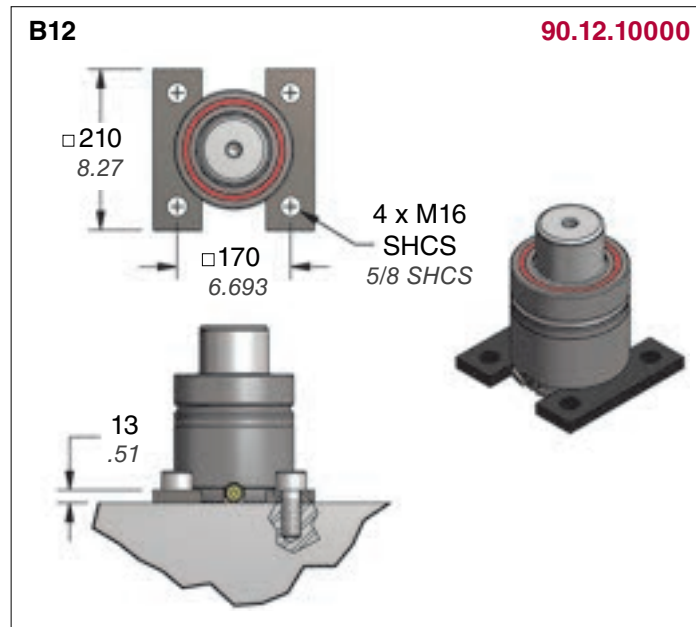

Ordering Example:

Cylinder with Mount: U.20000.025.B12.C.150

Mount Only: 90.12.10000

Alternative Mount

B19

SLIDE MOUNT INTO DESIRED LOCATION AND LOCK

90.19.____

Model	0600	0800	1000	2600	4600	6600	9600	20000
Part No.	00300	00500	00750	01500	03000	05000	07500	10000
A	95 3.74	100 3.94	130 5.12	160 6.30	195 7.68	220 8.66	260 10.24	310 12.20
B	43 1.69	46 1.81	60 2.36	75 2.95	92.5 3.64	105 4.13	125 4.92	150 5.91
D	34 1.34	37 1.457	50 1.97	63.5 2.50	80 3.15	92.5 3.64	110 4.33	135 5.31
E	77 3.031	82 3.228	110 4.331	137 5.394	170 6.693	195 7.677	230 9.055	2380 11.023
F	18 .71	18 .71	20 .79	22.5 .89	25 .98	27.5 1.08	30 1.18	30 1.18
G	M8 5/16	M8 5/16	M8 5/16	M10 3/8	M12 1/2	M12 1/2	M12 1/2	M12 1/2
H	M8	M8	M8	M10	M12	M12	M12	M12
J	50.3 1.98	60 2.36	80 3.15	105 4.13	125 4.92	148 5.83	200 7.87	250 9.84
K	27.5 1.08	30 1.18	40 1.57	52.5 2.06	62.5 2.46	74 2.91	100 3.94	125 4.92

Accessories

Test Stands

90.305.2 / 2D (2D Supplied with Digital Load Cell)
(U.0175-U.1600)

90.305.3 (U.0600 - U.6600)

Use the test stands in conjunction with a Standard Load Cell or Digital Load Cell for precise measurement of spring force on contact. For more information contact DADCO.



DADCO Electronic Pressure Monitor

DADCO's Electronic Pressure Monitors indicate if pressure drops below a preset level, alerting the press controller to shut down the press. They are available in a variety of configurations to suit a various applications. For more information, request bulletin B10105B or contact DADCO.



Digital Load Cell

90.305.BGA (Meter)

90.305.LC.05A (22.2 kN Load Cell)

90.305.LC.50A (222 kN Load Cell)

The 90.305.BGA meter can display force in Newtons, Kg or lbs. When paired with the 90.305.LC.05A Load Cell it may be used to measure gas spring force up to 5,000 lbs. When paired with the 90.305.LC.50A Load Cell gas spring force can be measured up to 50,000 lbs. For more information request bulletin B04106E.



90.305.BGA



90.305.LC.05A

90.305.LC.50A

Accessories & Repair Tools

Standard Load Cell

90.300.0175 (U.0175)	90.300.1000 (U.1000)	90.300.4600 (U.4600)
90.300.0325 (U.0325)	90.300.1200 (U.1200)	90.300.6600 (U.6600)
90.300.0300 (U.0400)	90.300.01500 (U.1600)	90.300.9600 (U.9600)
90.300.0500 (U.0600)	90.300.2600 (U.2600)	90.300.20000 (U.20000)
90.300.0750 (U.0800)		



The Standard Load Cell gives precise measurement of gas spring charging pressure. Each model requires its specified load cell. Load cells for the U.0175 - U.6600 may be used with the Portable Test Stand; load cells for the U.9600 and U.20000 may be used with an arbor press.

DADCO Repair Tool Kits

DADCO's most popular repair tools are now available in boxed sets for each of our three main classifications of nitrogen gas springs: Micro, Mini and Large Series. Kits may include DADCO load cells, charging nipples and various repair tools. Separate repair tool and load cell sets are also available. For more information request bulletin B05143B.



**DADCO Pressure Analyzer
90.315.5**

Use the DADCO Pressure Analyzer to easily charge, discharge, and gauge the pressure in DADCO's U Series Gas Springs. Not recommended for gauging the pressure in the U.0175 and U.0325. For more information request bulletin B01133F.



T-Handle

- 90.320.1 (M6: U.0400)**
- 90.320.2 (M8: U.0600 - U.9600)**
- 90.320.10 (M10: U.20000)**

To remove the piston rod when disassembling and position correctly when reassembling.



**Quick Disconnect Charging Nipple
90.310.143 (M6: U.0175-U.2600)
90.310.111 (G 1/8: U.4600-U.20000)**

Use the DADCO Quick Disconnect Charging Nipple to charge self-contained U Series Gas Springs. For more information contact DADCO.

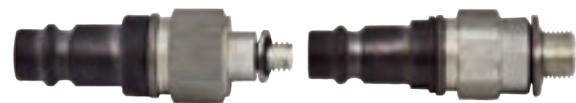

90.310.143

90.310.111

**Quick Disconnect Charging Assembly
90.310.040 (CA-40)**

Use the DADCO Quick Disconnect Charging Assembly, 90.310.040, with the 90.310.143 or 90.310.111 Charging Nipple or 90.315.5 Pressure Analyzer to charge self-contained gas springs. The 90.310.040 can also be used with a DADCO control panel to charge linked systems. The 90.310.040 includes the 90.310.201 Pressure Regulator, 90.310.252 Hose Assembly and the 90.310.338 Quick Disconnect Filling Assembly.

DADCO recommends using the 90.310.044 High Pressure Charging Assembly to charge U.0175 - U.0400 Nitrogen gas springs to maximum pressure. Request bulletin B16118B for more information.



Hose Assembly
3m (10 feet)
90.310.252

Pressure
Regulator
90.310.201

Quick Disconnect
Filling Assembly
90.310.338

Repair Tools

C-Ring Installation Tool

90.352 (U.1000, U.1600 - U.20000)

To insert the C-style retaining ring into the retaining ring groove.



C-Ring Removal Tool

**90.355 (U.0400 - U.0800, U.1200, U.1600, U.2600)
90.356 (U.1000, U.1600 - U.20000)**

To remove C-style retaining rings safely in a single controlled motion.



90.355



90.356

C-Ring Installation Tool

90.351.00400 (U.0400)

90.351.00300 (U.0600)

90.351.00500 (U.0800)

90.351.00750 (U.1200)

To insert the C-style retaining ring into the retaining ring groove.



Removal Sleeve

90.340.00400 (U.0400)

90.340.00600 (U.0600)

90.340.00750 (U.0800)

90.340.01200 (U.1000 / U.1200)

90.340.01600 (U.1600)

90.340.01500 (U.2600)

90.340.03000 (U.4600)

90.340.05000 (U.6600)

90.340.07500 (U.9600)

90.340.10000 (U.20000)

To position the cartridge below the C-ring groove when assembling or disassembling a gas spring.



Cartridge Starter Kit

90.335 (U.9600 - U.20000)

The Cartridge Starter Kit includes an Assembly Cap and an Assembly Cone. The Assembly Cone is used to start the cartridge assembly onto the rod without damaging the seal, the Assembly Cap is used to set the cartridge at a proper depth for C-Ring installation.

Other models available upon request.



Valve Bleed Tool

90.360.4

Use the DADCO Valve Bleed Tool to slowly discharge a spring to the desired pressure. For more information contact DADCO.



Port Servicing Tool

90.320.8

To perform all necessary servicing to the valve compartment. For more information request bulletin B05110A.



Repair Kits

Includes a fully assembled cartridge, dust cover, bottle of assembly oil and a maintenance manual.

<u>Model</u>	<u>Kit Number</u>	<u>Model</u>	<u>Kit Number</u>
U.0400	90.108.00400	U.2600	90.108.02600
U.0600	90.108.00600	U.4600	90.108.04600
U.0800	90.108.00800	U.6600	90.108.06600
U.1000	90.108.01000	U.9600	90.108.09600
U.1200	90.108.01200	U.20000	90.108.20000
U.1600	90.108.01600		



U.0400 - U.20000 Parts List

Dust Cover
90.246.U. _____
Model

O-Ring Backup Ring

O-Ring

UltraPak® Cartridge
90.200.U. _____
Model

Tube Assembly
90.205.U. _____
Model Stroke

U.4600 - U.9600

Port Plug
90.505.110

Piston Rod
90.215.U. _____
Model Stroke

Wiper

C-Style Retaining Ring

Model	Part Number
U.0400	90.285.U.0400
U.0600	90.285.3.0300
U.0800	90.285.3.0500
U.1000	90.285.00750
U.1200	90.285.3.0750
U.1600	90.285.U.1600
U.2600	90.285.01500
U.4600	90.285.03000
U.6600	90.285.05000
U.9600	90.285.07500
U.20000	90.285.10000

Compact Valve
90.260

U.0400 - U.2600

M6 Port Plug
90.607.110

Compact Valve
90.260

U.20000

Port Plug
90.505.110

Compact Valve
90.260

Cartridge Valve
90.265

Part Ordering Example:

Piston Rod: 90.215. U. 0400. 025

Part Number _____
Series _____

Stroke (mm)

Model: 0400, 0600, 0800, 1000, 1200,
1600, 2600, 4600, 6600, 9600, 20000

Note: The U Series Nitrogen Gas Springs are permanently marked with model number, serial number and repair kit number. Please refer to these when ordering replacement parts.

U.0175 and U.0325 gas springs may be recharged but not disassembled.

Converting from Self-Contained mode to Linked mode

CAUTION

Always wear safety glasses when maintaining nitrogen gas springs. When exhausting pressure, place the gas spring with the port up for safety.

U.0175 – U.0325 (M6 port)

Exhausting the Spring

- Keeping the face and hands clear of the port, depress the valve stem using the Valve Bleed Tool (90.360.4) detailed on page 32 (A.1).
- After all the gas pressure is exhausted, be sure that the piston rod will retract into the tube manually. If not, try depressing the valve stem again. If still unsuccessful **STOP** and contact your DADCO Service Representative.

Ready to Pipe

- Install a port adapter (90.607.122 or 90.607.038) into the open port (A.2). Contact DADCO for more information.

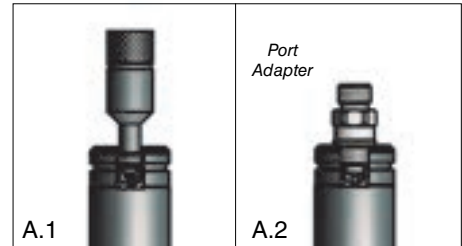

U.0400 – U.2600 (M6 port)

Remove Screw

- Remove the protective screw from the M6 port (B.1).

Exhausting the Spring

- Keeping the face and hands clear of the port, depress the valve stem using the Valve Bleed Tool (90.360.4) detailed on page 32 (B.2).
- After all the gas pressure is exhausted, be sure that the piston rod will retract into the tube manually. If not, try depressing the valve stem again. If still unsuccessful **STOP** and contact your DADCO Service Representative.

Remove Compact Valve

- Remove the Compact Valve (90.260) by unscrewing it using the Port Servicing Tool (90.320.8) detailed on page 32 (B.3).

Ready to Pipe

- Install a port adapter into the open M6 port (B.4). A wide variety of port adapters and fittings are available, contact DADCO for more information.

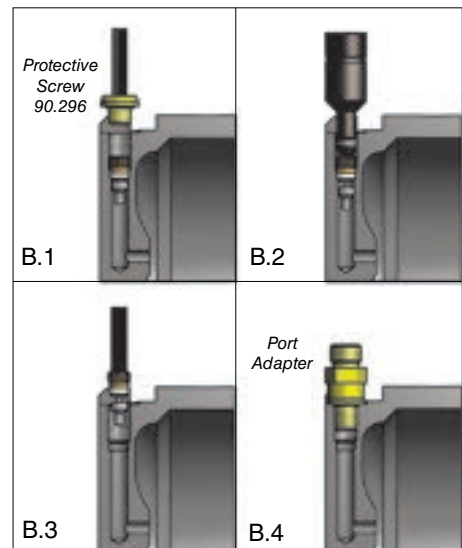

U.4600 – U.20000 (G 1/8 port)

Remove Port Plug

- Remove port plug (C.1).

Exhausting the Spring

- Keeping face and hands clear of the port, depress the valve stem using the Valve Bleed Tool (90.360.4) detailed on page 32 (C.2).
- After all the gas pressure is exhausted, be sure that the piston rod will retract into the tube manually. If not, try depressing the valve stem again. If still unsuccessful **STOP** and contact your DADCO Service Representative.

Remove Compact or Cartridge Valve

- Remove the Compact Valve (90.260) or Cartridge Valve (90.265) by unscrewing it using the Port Servicing Tool (90.320.8) detailed on page 32 (C.3).

Ready to Pipe

- Install a port adapter into the open G 1/8 port, (C.4). A wide variety of port adapters and fittings are available, contact DADCO for more information.

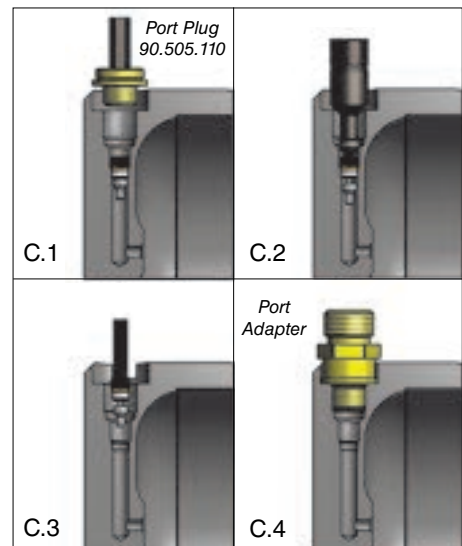

Technical Data

Operating Specifications

Charging Medium:	Nitrogen Gas
U.0175 – U.0400 Charging Pressure:	15 – 180 bar (220 psi – 2600 psi)
U.0600 – U.20000 Charging Pressure:	15 – 150 bar (220 psi – 2175 psi)
Operating Temperature:	4°C – 71°C (40°F – 160°F)
Maximum Speed:	1.6 m/sec (63 in/sec)

CAUTION
DO NOT attempt maintenance on spring until internal pressure is exhausted.

Installation Requirements

Avoid Sudden Release

- Jammed parts are very dangerous. If parts are jamming, determine the root cause and repair it before production continues. Sudden release may cause gas to exhaust. Slightly preloading the gas spring (F.1) prevents spring damage and sudden release (F.2).

Provide Stroke Reserve

- DADCO U Series gas springs will permit travel of the full nominal stroke; however, at least a 10% stroke reserve is recommended to achieve optimal performance and safety (F.3 and F.4).

Avoid Side Loading

- A misaligned press or die can cause side loading that increases wear on the bearing, seal, and piston rod (F.6). Therefore, avoid side loading when possible (F.5).

Rod End Thread (U.0400 - U.2000)

- The end of the piston rod has a construction thread intended for assembly and disassembly purposes only, and should never be used to mount or secure the gas spring (F.6). Die vibration and/or misalignment will damage the spring.

Protect From Fluids

- Direct contact with certain die lubricants and cleaners should be avoided (F.8). Protect gas springs by providing adequate drainage in gas spring pockets (F.7).

Discharging Self-Contained Gas Spring

- Refer to page 34 for information on how to discharge U.0175 and U.0325 gas springs.
- The DADCO Pressure Analyzer (90.315.5) detailed on page 31, allows for charging, discharging and gauging of the pressure in the U.0400 - U.20000 gas springs (F.9). For information on completely exhausting the gas spring see page 34.

Recharging Self-Contained Gas Spring

- Refer to the Micro Catalog (C12118B) for information on how to charge U.0175 and U.0325 gas springs.
- Hold the spring vertically at all times during filling. Never compress the gas spring in a vice or clamp outside of the die or application as damage to the gas spring can result (F.10).
- Never fill a gas spring unless the rod is in the fully extended position (F.12). Thread the T-handle (90.320.1, 90.320.2 or 90.320.10) detailed on page 31, into the rod end and depress the valve stem with the Valve Bleed Tool (90.360.4) or Port Servicing Tool (90.320.8), detailed on page 32. Pull the rod cartridge assembly up until it is seated firmly against the retaining ring (F.11). Remove the T-handle from the rod and charge the gas spring to the desired pressure. Refer to DADCO's U Series Maintenance Instructions for complete step-by-step instruction.

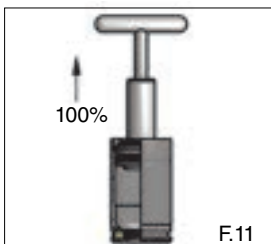
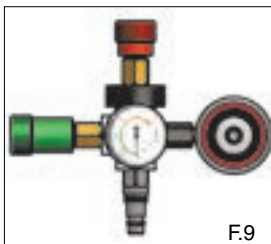
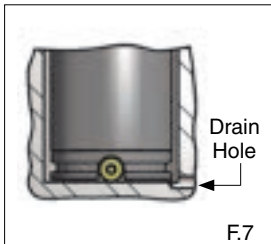
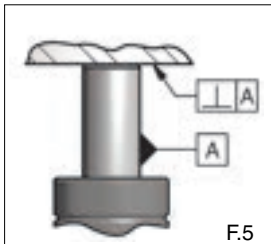
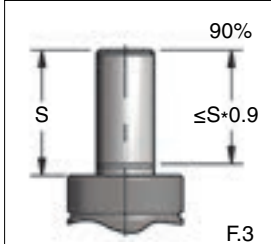
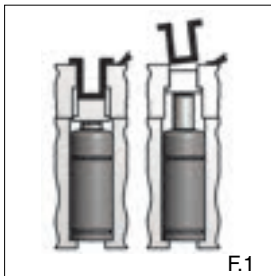
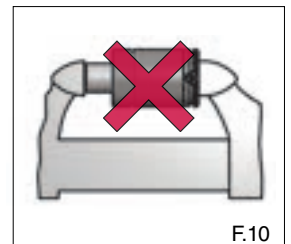
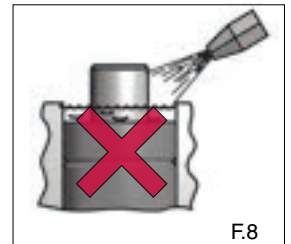
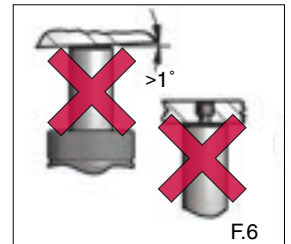
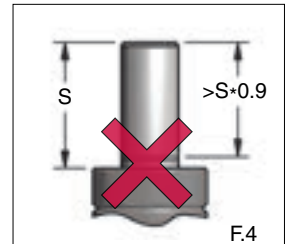
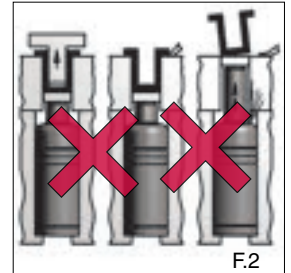

THE ULTIMATE SPACE SAVING SOLUTION!



The **Ultra Force®** Series provides the highest force available in compact height nitrogen gas springs!

- Up to 22 tons of Force on Contact
- Available in Diameters from 19 mm to 195 mm
- Full Range of Stroke Sizes
- Superior Seal and Bearing Design
- Less Cylinders = Same Force
- Lower Design and Tooling Costs

DADCO®

43850 Plymouth Oaks Blvd. • Plymouth, Michigan • 48170 • USA
734.207.1100 • 800.DADCO.USA • fax 734.207.2222 • www.dadco.net

The global leader in nitrogen gas spring technology