

CAUTION: Always wear safety goggles when performing maintenance work.

SLC.500 / SLC.800 Nitrogen Gas Spring Rail Lifter Repair Instructions

I. Exhausting Pressure



1. Exhaust nitrogen gas by opening the bleed valve on the Convertible Control Panel (90.406.____).



2. Verify all pressure is relieved by manually retracting piston rod into tube. If the rod will not fully retract, release remaining pressure. If still unsuccessful, **STOP** and contact DADCO. **NOTE:** SLC Lifters have rod extensions (15 mm for SLC.500, 25 mm for SLC.800) that will remain above cylinder mouth when exhausted.



3. Loosen Port Adapter using a 5/8" wrench for the 90.505.115 and a 14 mm wrench for the 90.508.115. Unthread the Port Adapter and wipe with a clean cloth. Inspect the adapter and replace if it shows signs of damage. Set aside for reassembly. Check the port for deposits or burrs and clean thoroughly.



4. Remove Mount and save components for reassembly.

II. C-Ring Removal



1. Stand lifter upright. Place Removal Sleeve (90.340.00750 for SLC.500, 90.341.00800 for SLC.800) over rod. Tap sleeve until Dust Cover (90.246.x) is loosened. Remove Dust Cover and discard.



2. Reposition the Removal Sleeve and continue tapping until Cartridge Assembly is slightly below retaining ring groove.



3. Remove C-Style Retaining Ring (90.285.x) using C-Ring Removal Tool (90.356.SLN). Position hooked end of C-Ring Removal Tool below c-ring. For best results locate tool near either end of c-ring.



4. Once hooked end of tool is firmly seated below c-ring, begin pushing it toward outside of the Tube Assembly. The handles will close naturally and the c-ring will be extracted as you complete this motion. Retain for use during reassembly.

III. Rod & Cartridge Removal



1. To remove rod and cartridge assembly, thread the T-Handle (90.320.x) into rod end.



2. Pull entire assembly out of the Tube Assembly. Remove T-Handle.



3. Remove the Retainer Wear Ring (90.242.x) from the Rod Retainer (90.225.x).



4. Remove the two halves of the Rod Retainer. Clean Rod Retainer and Retainer Wear Ring, set aside for reassembly.



5. Tap or slide Cushion Collar Assembly (90.235.x) off rod from piston end and discard.

IV. Cleaning & Inspection



1. Slide the Cartridge Assembly (90.230.x) off of rod and discard.



2. Lightly polish rod surface with an emery cloth (600 grit). Polish out any scratches. Inspect finish of the rod for any scratches or gouges. If the rod is damaged, it must be replaced.



3. Inspect Tube Assembly for damage. Polish out any scratches at the mouth of the tube assembly. If damage to Tube Assembly is severe, it must be replaced. Wash, clean and dry the inside thoroughly.



4. Lubricate threads on the adapter and thread it into port.

V. Rod Sub Assembly

CAUTION: Before starting the reassembly process, be sure the repair area is clean. It is imperative that the gas spring rail lifter be free of all contaminants upon reassembly. If this precaution is not taken it may lead to premature failure of the rail lifter.



1. Position new Cartridge Assembly over rod with the wiper end marked "TOP" facing up. Slide cartridge down the rod toward piston end.



2. Tap new Cushion Collar Assembly onto rod from piston end using a soft rubber mallet or arbor press. Seat collar against rod safety ring squarely.



3. Replace the two halves of the Rod Retainer behind Cushion Collar Assembly. If retainer will not install, **STOP** and contact DADCO.



4. Add Retainer Wear Ring. Apply extra oil to cushion collar seal, the cartridge o-ring and inside of cartridge.

VI. Cartridge Replacement and Reassembly



1. Lubricate inside wall of tube with entire contents of bottle of assembly oil. Place Rod Sub-assembly into Tube Assembly.



2. Place Removal Sleeve (90.340.x) over rod. Tap sleeve until Cartridge Assembly is slightly below retaining ring groove.



3. Insert the C-Style Retaining Ring in the retaining ring groove with C-Ring Installation Tool (90.350.00750) for the SLC.500 or by hand for the SLC.800. Be sure c-ring is fully seated in retaining ring groove.



4. Thread the T-Handle (90.320.x) into the end of the Piston Rod. Pull up on T-Handle until top of the cartridge is past the c-ring. Make sure rod is extended to its proper stroke length.



5. Slide bottom half of mount on can below snap ring groove. Insert two-piece snap ring set and lightly tap into groove.

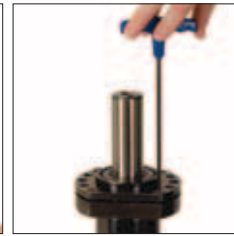

6. Slide top half of mount on can until it engages snap rings. Lift up on bottom half of mount until it too engages snap rings. Bolt top and bottom pieces together using the four original screws.

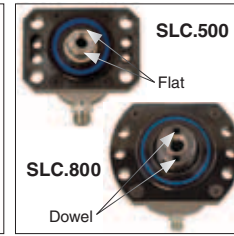

7. Align mount, rod and port adapter as pictured.

VII. Charging

NOTE: For best results, use DADCO's Charging Assembly which has a shut off valve and a quick disconnect at the end of the hose.



1. Pipe all gas lifters back to Convertible Control Panel (90.406.____) making sure all connections are tight and gas lifter rods are extended.



2. Attach Charging Assembly (90.310.040) to quick disconnect filler valve on the control panel and close shut-off valve.



3. Open main valve on the nitrogen tank. Set desired pressure on the pressure regulator. Slowly open shut-off valve on control panel and allow each lifter to reach desired charging pressure.



4. Close control panel shut-off valve and tank shut-off valve. Disconnect the charging assembly from the Common Control Panel.

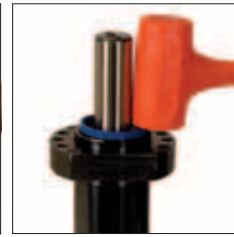

5. Install new Dust Cover (90.246.x). Tap with soft rubber mallet until top of Dust Cover rests flush with top of can.

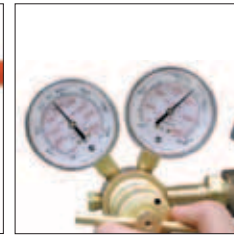

1. To increase system pressure, set regulator on nitrogen tank to desired level and fill system through control panel.



2. To release pressure, open drain valve on the control panel.

VIII. Adjusting Pressure

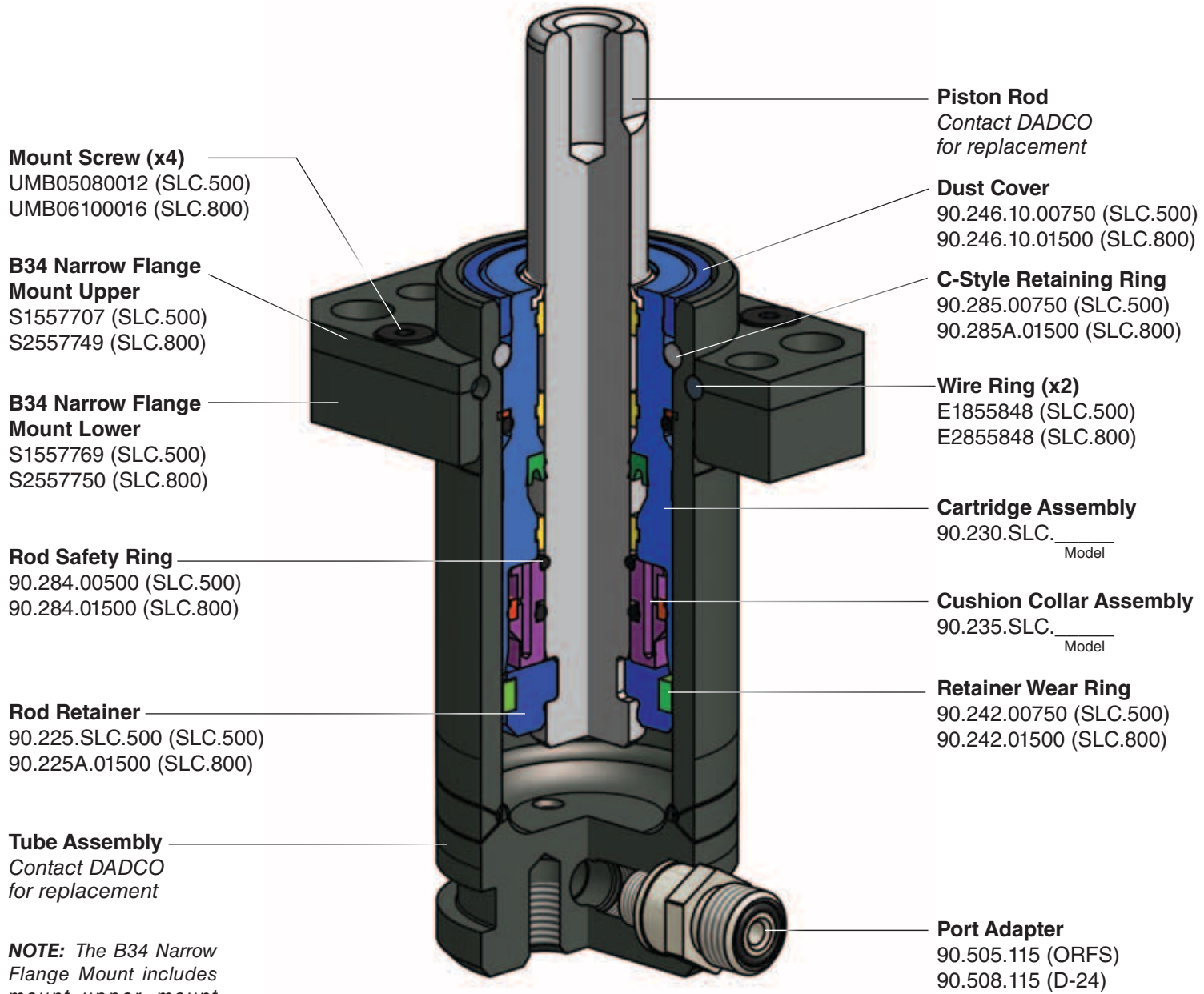

SLC Repair Kits
DADCO's SLC Repair Kits include a dust cover, cushion collar assembly, cartridge assembly, bottle of assembly oil and maintenance manual.

Model	Part No.
SLC.500	SLC.RK.500
SLC.800	SLC.RK.800

Repair Tools

C-Ring Removal Tool
90.356.SLN

To remove the C-Style Retaining Ring safely in a single controlled motion.



Removal Sleeve
90.340.00750 (SLC.500)
90.341.00800 (SLC.800)

To position the cartridge below the c-ring groove when assembling or disassembling SLC Series Nitrogen Gas Spring Rail Lifters.



C-Ring Installation Tool
90.350.00750

To insert the C-Style Retaining Ring into the retaining ring groove of the SLC.500.



T-Handle
90.320.10 (M10)
90.320.12 (M12)
90.320.16 (M16)

To remove the Piston Rod when disassembling and position correctly when reassembling.



Convertible Control Panel
90.406.____

The Convertible Control Panel is used to fill, drain and monitor the pressure of linked DADCO Nitrogen Gas Spring Rail Lifters from outside the die. For more information request bulletin B08103.



90.406.P1N Shown

Charging Assembly
90.310.040

Use the DADCO Quick Disconnect Charging Assembly with a DADCO Common Control Panel for charging SLC Series Nitrogen Gas Spring Rail Lifter linked systems. For more information contact DADCO.



DADCO
Nitrogen Gas Spring Rail Lifter Maintenance Instructions
SLC.500 and SLC.800



Comprehensive Guide

This service manual is a simple step-by-step maintenance guide for DADCO's SLC.500 and SLC.800 Nitrogen Gas Spring Rail Lifters. Proper repair requires careful examination of all component parts and replacement of any that are worn or damaged. All DADCO replacement parts are available from factory stock.

NOTE: DADCO's SLC Nitrogen Gas Spring Rail Lifters are permanently marked with model number, serial number and repair kit number. Please refer to these numbers when ordering replacement parts.

DADCO
43850 Plymouth Oaks Blvd.
Plymouth, Michigan USA 48170
1.734.207.1100 • 800.323.2687
fax 1.734.207.2222
www.dadco.net