

# DADCO®

## High Force Nitrogen Gas Springs

## UK Series



- Up to 2.6 tons of force on contact
- Common G 1/8 port across models
- Longer tapped threads for base mounting





The global leader in nitrogen gas spring technology

DADCO produces top quality products at competitive prices and provides a superior level of customer service. Founded in 1958, DADCO is the highest volume producer of gas springs for press tools. DADCO's products are widely approved and used in global operations for many industries including metal stamping, automotive and plastic injection molding.

**UK Series**

Using the popular **Ultra Force®** (U) Series technology, the UK Series features four models with common G 1/8 ports for linked operations and longer tapped threads for base mounting. A variety of stroke lengths and mount options may be chosen to accommodate new or existing applications.

Models	Diameter	Overall Length	Maximum Force on Contact
UK.0800	44.5 mm (1.750")	(2 x Stroke) + 42	1655 lb. (736 daN)
UK.1000	50 mm (1.968")	(2 x Stroke) + 48	2076 lb. (924 daN)
UK.1600	63 mm (2.480")	(2 x Stroke) + 54	3432 lb. (1527 daN)
UK.2600	75 mm (2.953")	(2 x Stroke) + 55	5362 lb. (2386 daN)

**High Quality Construction**

To ensure their exceptionally long service life, DADCO's UK Series Gas Springs have high quality construction features. All models are built with a one-piece piston rod and utilize a double lip rod seal for excellent load capacity and resistance to wear.



**Adjustable Force**

For convenience, self-contained cylinders usually are delivered pre-charged to the desired force and ready to install. If force adjustment is ever needed, a filling/draining port is located in the cylinder for safe, easy access.

**Numerous Piping Options**

Many customers have recognized the benefits of piping gas springs to monitor, control, and adjust force from outside the die. DADCO offers a wide selection of hoses, fittings, control panels and equipment to simplify the piping process. For additional information on piping refer to DADCO's Nitrogen Gas Spring Linked System Components Catalog.



**Customer Satisfaction**

DADCO's motto is "Whatever It Takes To Satisfy Our Customers." DADCO will assist in any way possible to ensure that customers are completely satisfied. DADCO's salespeople and distributors are solution-oriented, product-knowledgeable, and eager to assist customers. DADCO's engineers are available to help customers with specific applications.

**Rapid Delivery**

DADCO's modern 13,150 m<sup>2</sup> main production facility as well as satellite facilities permit the fastest deliveries in the industry. Products are available both directly and through a network of trained distributors providing worldwide support.

**Warranty**

DADCO warrants its UK Series Nitrogen Gas Springs to be free from defects in workmanship or materials for a period of one year from date of manufacture.

# Installation Examples

DADCO offers a variety of mount options to meet specific customer applications. Installation and fastening of the gas springs should take into consideration load support, fastener selection and torque values. For additional information on installation requirements see page 12. Cylinder and mount dimensions are shown on pages 4-11.

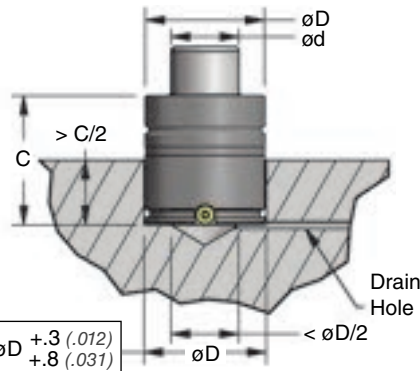

**TO Basic Model** in a flat bottom pocket. The pocket must be bored with a flat bottom, or a spacer must be used to create a flat surface.

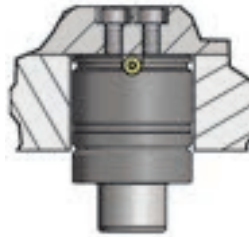

**TO Basic Model** mounted inverted requires back-up to support the full load. Retain inverted cylinders tight in the pocket with the appropriate length cap screw to eliminate movement.

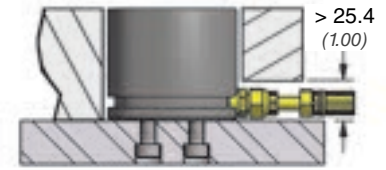

**TO Basic Model** mounted to a plate. Linked cylinders require clearance for the hose and fittings.

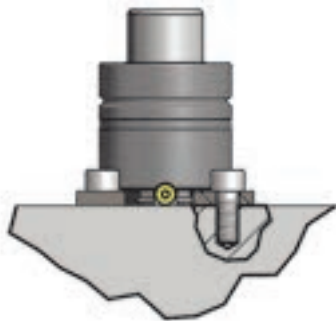

**B12/B112/B212/B312** mounts must be fastened to the bottom groove only. Back-up is required to support the full load.

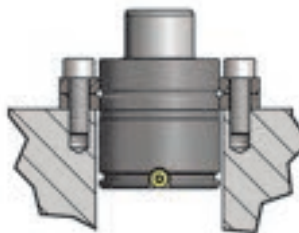

**B21/B421/B25/B425** mounts must be fastened to the top groove only. The wire ring supplied with mounts supports the full load.

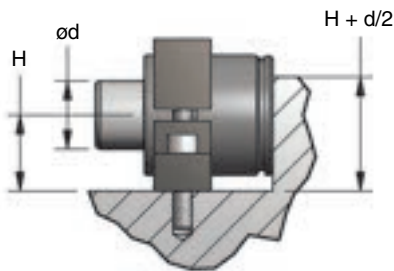
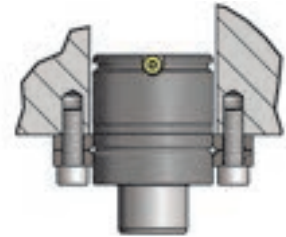

**B319V** mounts require back-up to support the load.

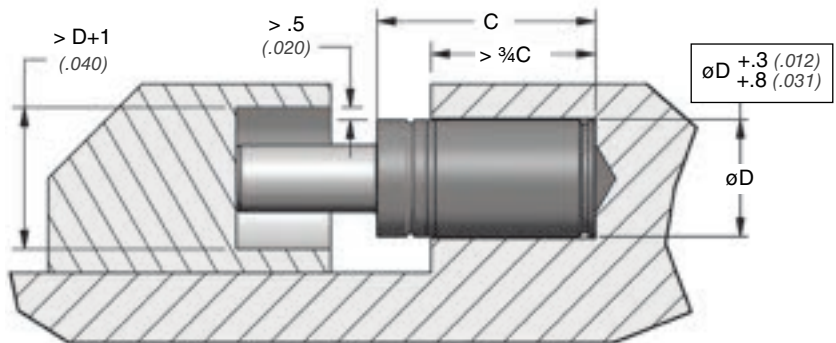

**TO Basic Model** mounted in a horizontal pocket. Allow clearance in the rod pocket to avoid contacting the body of the cylinder during operation. Allow the rod to locate freely.

**SMS® / SMS-i®** DADCO offers customized Sectional Mounting Systems (SMS® and SMS-i®) which are fabricated to customer specifications, pressure tested and shipped ready to install.

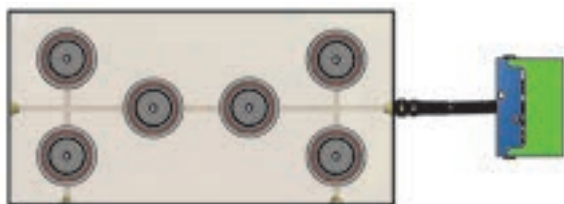

DADCO SMS-i® with (6) UK.1600 gas springs plumbed internally and connected to a control panel.



DADCO SMS® with (4) UK.2600 gas springs linked using 90.400 (Y-400) hose, fittings and a control panel.

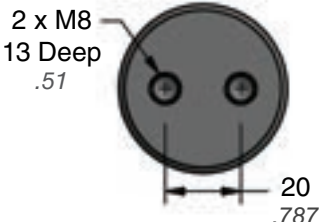
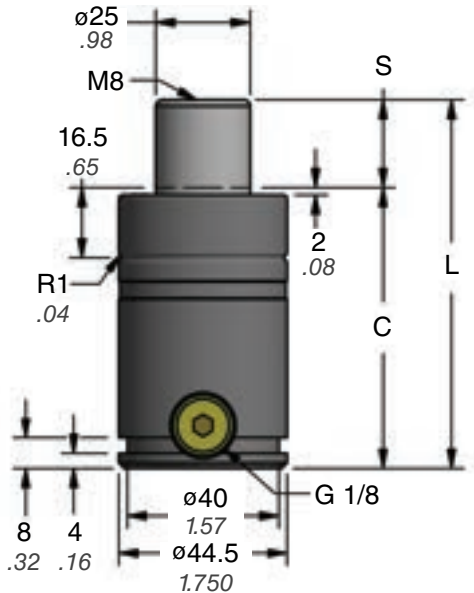

**TO - Basic Model**

Part No.	S mm inch	C	L ±0.25 ±0.010
• UK.0800.013	12.5 0.49	54.5 2.15	67 2.638
UK.0800.016	16 0.63	58 2.28	74 2.913
UK.0800.019	19 0.75	61 2.40	80 3.150
• UK.0800.025	25 0.98	67 2.64	92 3.622
UK.0800.032	32 1.26	74 2.91	106 4.173
• UK.0800.038	37.5 1.48	79.5 3.13	117 4.606
• UK.0800.050	50 1.97	92 3.62	142 5.591
UK.0800.063	62.5 2.46	104.5 4.11	167 6.575
UK.0800.075	75 2.95	117 4.61	192 7.559
• UK.0800.080	80 3.15	122 4.80	202 7.953
UK.0800.100	100 3.94	142 5.59	242 9.528
UK.0800.125	125 4.92	167 6.57	292 11.496

• Preferred Sizes

**Ordering Example:**

**UK.0800.025. TO. C. 150**

**Part Number:** Includes Series, Model and Stroke Length.

**Mount Option:** TO = Basic Model. When not specified, default is TO. B319V, B21 and B25 mounts ordered with cylinder will be attached at the factory.

**Charging Pressure:** 15–150 bar (220–2175 psi). When not specified, default is 150 bar.

**Operating System:** C = Self-contained, F = Open Flow Fitting. When not specified, default is C, self-contained.

**736 daN / 0.7 ton**

**Force Charts**

**On-Contact Force**

psi	lb.
2175	1655
2000	1522
1750	1331
1500	1141
1000	761
500	380
250	190

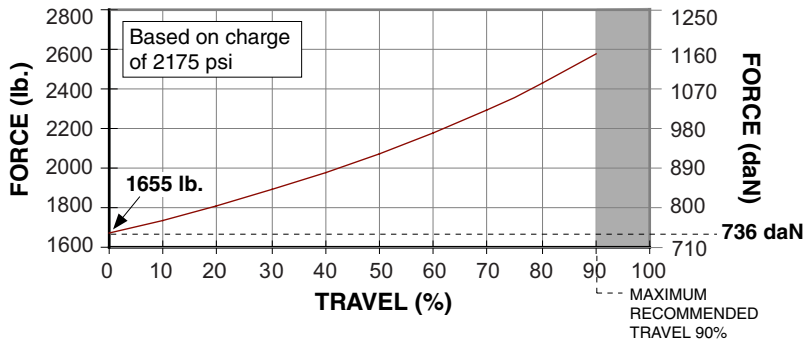

**On-Contact Force**

bar	daN
150	736
125	614
100	491
75	368
50	245
25	123
20	98

**Mount Options**

**B312** **90.312.00500**

□ 70  
2.76

□ 50  
1.968

4 x M8 SHCS  
5/16 SHCS

7  
.28

**B319V** **90.319V.0800**

2X M8x50 mm SHCS SUPPLIED

80  
3.15

60  
2.362

10  
.39

27.5  
1.08

20  
.79

22  
.87

60  
2.36

SLIDE MOUNT INTO DESIRED LOCATION AND SECURE USING THE TWO SHCS PROVIDED

**B21** **90.21.00500**

ø86  
3.39

ø70.7 BOLT CIRCLE  
2.783

4 x M8 SHCS  
5/16 SHCS

□ 50  
1.968

13  
.51

23  
.91

SECURE MOUNT ONTO TOP GROOVE WITH SUPPLIED RING AND SCREWS

Split Wire Ring Included  
90.55.3.500

**B25** **90.25.00500**

4 x M8 SHCS 5/16 SHCS

4 x M8 SHCS  
5/16 SHCS

□ 50  
1.968

□ 64  
2.52

13  
.51

23  
.91

SECURE MOUNT ONTO TOP GROOVE WITH SUPPLIED RING AND SCREWS

Split Wire Ring Included  
90.55.3.500

**Ordering Example:**

**Cylinder with Mount:** UK.0800.025.B312.C.150

**Mount Only:** 90.312.00500



**Force Charts**

**On-Contact Force**

psi	lb.
2175	2076
2000	1909
1750	1670
1500	1432
1000	954
500	477
250	239

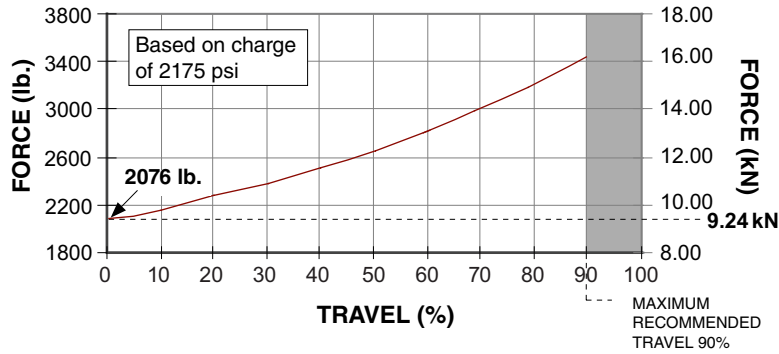

**On-Contact Force**

bar	kN
150	9.24
125	7.70
100	6.16
75	4.62
50	3.08
25	1.54
20	1.23

**Mount Options**

**B12** **90.12.00750**

4 x M8 SHCS  
5/16 SHCS

**B319V** **90.319V.1000**

2X M10x60 mm SHCS SUPPLIED

SLIDE MOUNT INTO DESIRED LOCATION AND SECURE USING THE TWO SHCS PROVIDED

**B21** **90.21.00750**

ø80 BOLT CIRCLE  
3.150

4 x M8 SHCS  
5/16 SHCS

Split Wire Ring Included  
90.55.10.750

SECURE MOUNT ONTO TOP GROOVE WITH SUPPLIED RING AND SCREWS

**B25** **90.25.00750**

4 x M8 SHCS  
5/16 SHCS

Split Wire Ring Included  
90.55.10.750

SECURE MOUNT ONTO TOP GROOVE WITH SUPPLIED RING AND SCREWS

**Ordering Example:**

**Cylinder with Mount:** UK.1000.025.B12.C.150

**Mount Only:** 90.12.00750

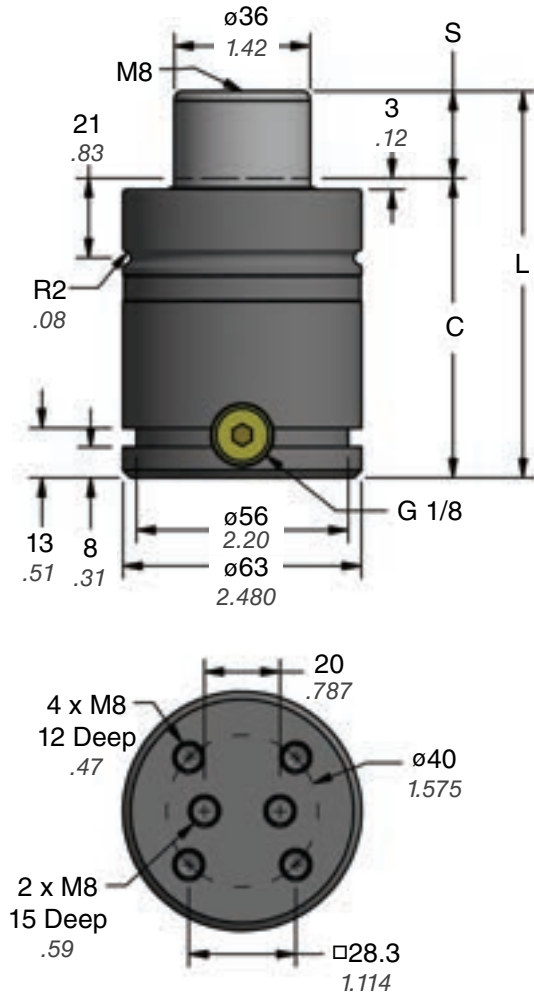

**TO - Basic Model**

Part No.	S mm inch	C	L ±0.25 ±0.010
• UK.1600.013	12.5 0.49	66.5 2.62	79 3.110
UK.1600.016	16 0.63	70 2.76	86 3.386
UK.1600.019	19 0.75	73 2.87	92 3.622
• UK.1600.025	25 0.98	79 3.11	104 4.094
UK.1600.032	32 1.26	86 3.39	118 4.646
• UK.1600.038	37.5 1.48	91.5 3.60	129 5.079
• UK.1600.050	50 1.97	104 4.09	154 6.063
UK.1600.063	62.5 2.46	116.5 4.59	179 7.047
UK.1600.075	75 2.95	129 5.08	204 8.031
• UK.1600.080	80 3.15	134 5.28	214 8.425
UK.1600.100	100 3.94	154 6.06	254 10.000
UK.1600.125	125 4.92	179 7.05	304 11.969

• Preferred Sizes

**Ordering Example:**

**UK.1600.025. TO. C. 150**

**Part Number:** Includes Series, Model and Stroke Length.

**Mount Option:** TO = Basic Model. When not specified, default is TO. B319V, B421 and B425 mounts ordered with cylinder will be attached at the factory.

**Charging Pressure:** 15–150 bar (220–2175 psi). When not specified, default is 150 bar.

**Operating System:** C = Self-contained, F = Open Flow Fitting. When not specified, default is C, self-contained.



**Force Charts**

**On-Contact Force**

psi	lb.
2175	3432
2000	3155
1750	2761
1500	2367
1000	1578
500	789
250	394

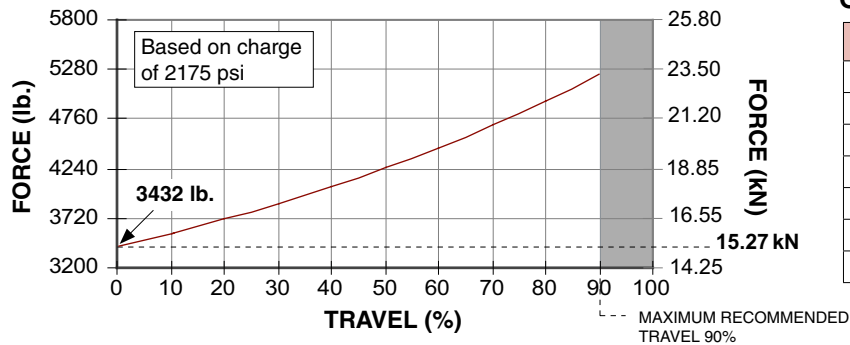

**On-Contact Force**

bar	kN
150	15.27
125	12.72
100	10.18
75	7.63
50	5.09
25	2.54
20	2.04

**Mount Options**

**B112 / 90.112.1600**      **B212 / 90.212.1600**

4 x M10 SHCS  
3/8 SHCS

Part No.	A	B
90.112.1600	85 (3.35)	60 (2.362)
90.212.1600	100 (3.94)	73.5 (2.894)

**B319V**      **90.319V.1600**

2X M10x70 mm SHCS SUPPLIED

SLIDE MOUNT INTO DESIRED LOCATION AND SECURE USING THE TWO SHCS PROVIDED

**B325**      **90.325.1600**

4 x M10 SHCS  
3/8 SHCS

Split Wire Ring Included  
90.55.U.1600

SECURE MOUNT ONTO TOP GROOVE WITH SUPPLIED RING AND SCREWS

**B425**      **90.425.1600**

4 x M10 SHCS  
3/8 SHCS

Split Wire Ring Included  
90.55.U.1600

SECURE MOUNT ONTO TOP GROOVE WITH SUPPLIED RING AND SCREWS

**Ordering Example:**

**Cylinder with Mount:** UK.1600.025.B112.C.150

**Mount Only:** 90.112.1600

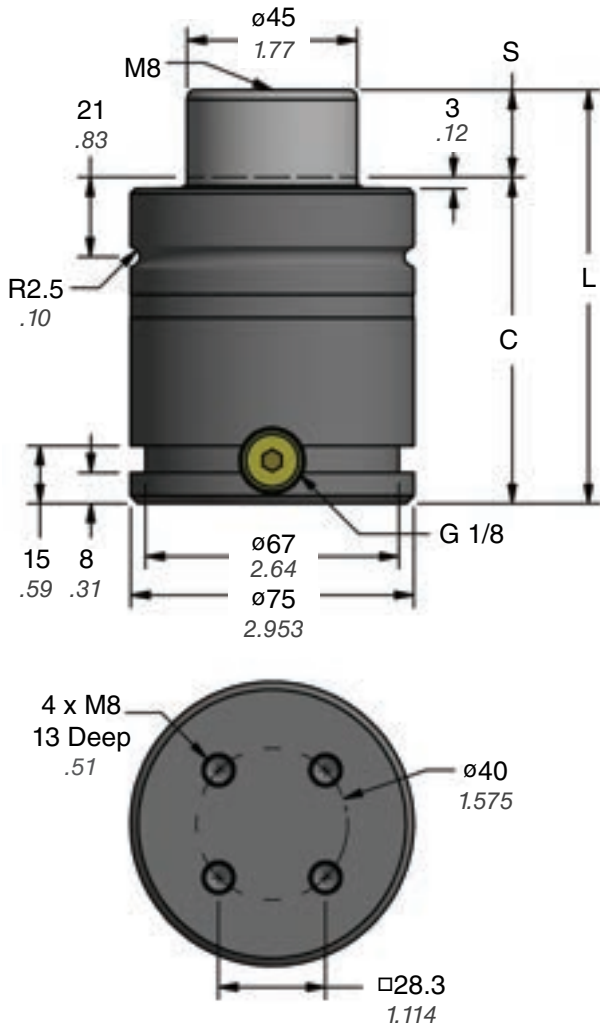

**TO - Basic Model**

Part No.	S mm inch	C	L ±0.25 ±0.010
UK.2600.016	16 0.63	71 2.80	87 3.425
UK.2600.019	19 0.75	74 2.91	93 3.661
• UK.2600.025	25 0.98	80 3.15	105 4.134
UK.2600.032	32 1.26	87 3.43	119 4.685
• UK.2600.038	37.5 1.48	92.5 3.64	130 5.118
• UK.2600.050	50 1.97	105 4.13	155 6.102
UK.2600.063	62.5 2.46	117.5 4.63	180 7.087
UK.2600.075	75 2.95	130 5.12	205 8.071
• UK.2600.080	80 3.15	135 5.31	215 8.465
UK.2600.100	100 3.94	155 6.10	255 10.039
UK.2600.125	125 4.92	180 7.09	305 12.008

• Preferred Sizes

**Ordering Example:**

**UK.2600.025. TO. C. 150**

**Part Number:** —  
Includes Series, Model and Stroke Length.

**Mount Option:** —  
TO = Basic Model. *When not specified, default is TO.*  
B319V, B21 and B25 mounts ordered with cylinder will be attached at the factory.

**Charging Pressure:**  
15–150 bar (220–2175 psi).  
*When not specified, default is 150 bar.*

**Operating System:** C = Self-contained,  
F = Open Flow Fitting. *When not specified, default is C, self-contained.*

**Force Charts**

**On-Contact Force**

psi	lb.
2175	5362
2000	4930
1750	4314
1500	3698
1000	2465
500	1233
250	616

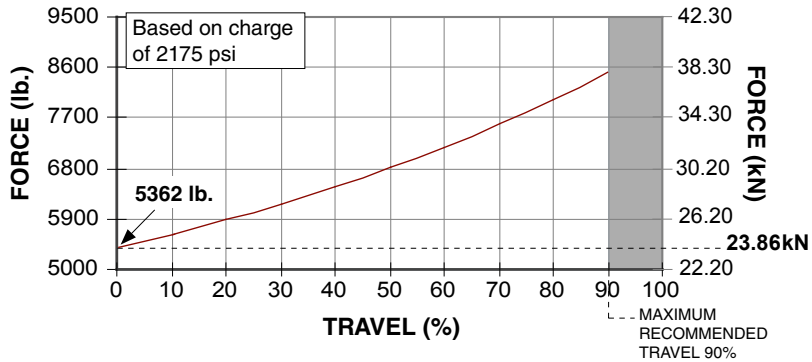

**On-Contact Force**

bar	kN
150	23.86
125	19.88
100	15.90
75	11.93
50	7.95
25	3.98
20	3.18

**Mount Options**

**B12** **90.12.01500**

4 x M10 SHCS  
3/8 SHCS

**B319V** **90.319V.2600**

2X M12x80 mm SHCS SUPPLIED

SLIDE MOUNT INTO DESIRED LOCATION AND SECURE USING THE TWO SHCS PROVIDED

**B21** **90.21.01500**

ø104 BOLT CIRCLE 4.094

4 x M10 SHCS 3/8 SHCS

Split Wire Ring Included 90.55.1500

SECURE MOUNT ONTO TOP GROOVE WITH SUPPLIED RING AND SCREWS

**B25** **90.25.01500**

4 x M10 SHCS 3/8 SHCS

Split Wire Ring Included 90.55.1500

SECURE MOUNT ONTO TOP GROOVE WITH SUPPLIED RING AND SCREWS

**Ordering Example:**

**Cylinder with Mount:** UK.2600.025.B12.C.150

**Mount Only:** 90.12.01500

# Technical Data

## CAUTION

DO NOT attempt maintenance on spring until internal pressure is exhausted.

## Operating Specifications

Charging Medium:	Nitrogen Gas
Models Charging Pressure:	15 – 150 bar (220 psi – 2175 psi)
Operating Temperature:	4°C – 71°C (40°F – 160°F)
Maximum Speed:	1.6 m/sec (63 in/sec)

## Installation Requirements

### Provide Stroke Reserve

- DADCO UK Series gas springs will permit travel of the full nominal stroke; however, at least a 10% stroke reserve is recommended to achieve optimal performance and safety (F.1 and F.2).

### Avoid Side Loading

- A misaligned press or die can cause side loading that increases wear on the bearing, seal, and piston rod (F.4). Therefore, avoid side loading when possible (F.3).

### Rod End Thread

- The end of the piston rod has a construction thread intended for assembly and disassembly purposes only, and should never be used to mount or secure the gas spring (F.4). Die vibration and/or misalignment will damage the spring.

### Protect From Fluids

- Direct contact with certain die lubricants and cleaners should be avoided (F.6). Protect gas springs by providing adequate drainage in gas spring pockets (F.5).

### Discharging Self-Contained Gas Spring

- The DADCO Pressure Analyzer (90.315.5) detailed on page 21, allows for charging, discharging and gauging of the pressure in the UH and UK Series gas springs (F.7). For information on completely exhausting the gas spring refer to DADCO's UH Series Maintenance Instructions.

### Recharging Self-Contained Gas Spring

- Hold the spring vertically at all times during filling. Never compress the gas spring in a vice or clamp outside of the die or application as damage to the gas spring can result (F.8).
- Never fill a gas spring unless the rod is in the fully extended position (F.10). Thread the T-handle (90.320.1 or 90.320.2) detailed on page 21, into the rod end and depress the valve stem with the Valve Bleed Tool (90.360.4) or Port Servicing Tool (90.320.8), detailed on page 22. Pull the rod cartridge assembly up until it is seated firmly against the retaining ring (F.9). Remove the T-handle from the rod and charge the gas spring to the desired pressure. Refer to DADCO's U/UH/UK Series Maintenance Instructions for complete step-by-step instruction.

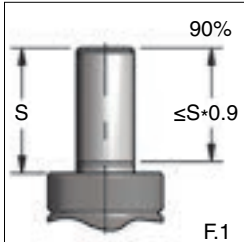

F.1

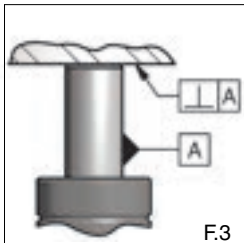

F.3

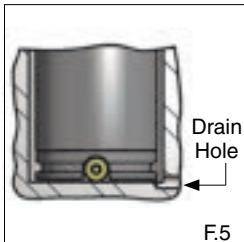

F.5

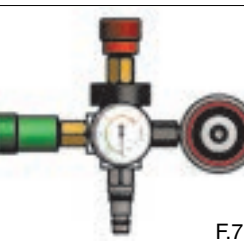

F.7

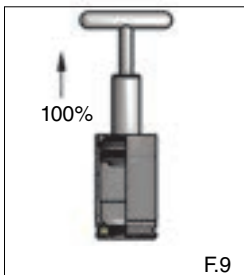

F.9

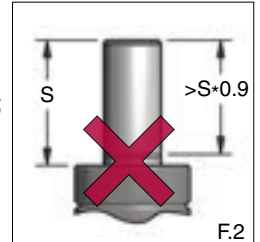

F.2

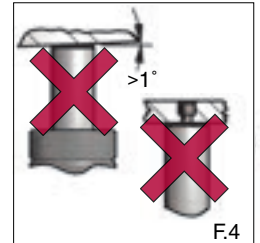

F.4

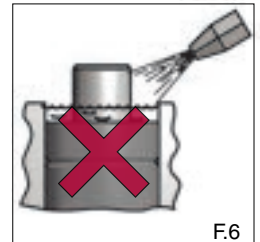

F.6

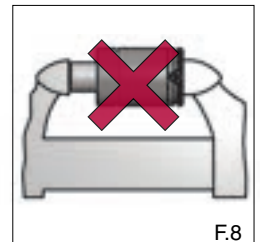

F.8

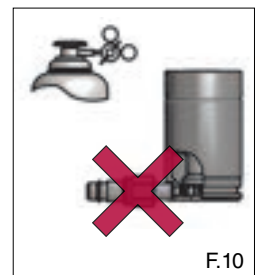

F.10

# DADCO®

43850 Plymouth Oaks Blvd. • Plymouth, Michigan • 48170 • USA  
734.207.1100 • 800.DADCO.USA • fax 734.207.2222 • www.dadco.net

**The global leader in nitrogen gas spring technology**